

5-2000

Engaged Learning in a Secondary Science Classroom

Holly Rubach

Southern Illinois University Carbondale

Follow this and additional works at: http://opensiuc.lib.siu.edu/uhp_theses

Recommended Citation

Rubach, Holly, "Engaged Learning in a Secondary Science Classroom" (2000). *Honors Theses*. Paper 77.

This Dissertation/Thesis is brought to you for free and open access by the University Honors Program at OpenSIUC. It has been accepted for inclusion in Honors Theses by an authorized administrator of OpenSIUC. For more information, please contact opensiuc@lib.siu.edu.

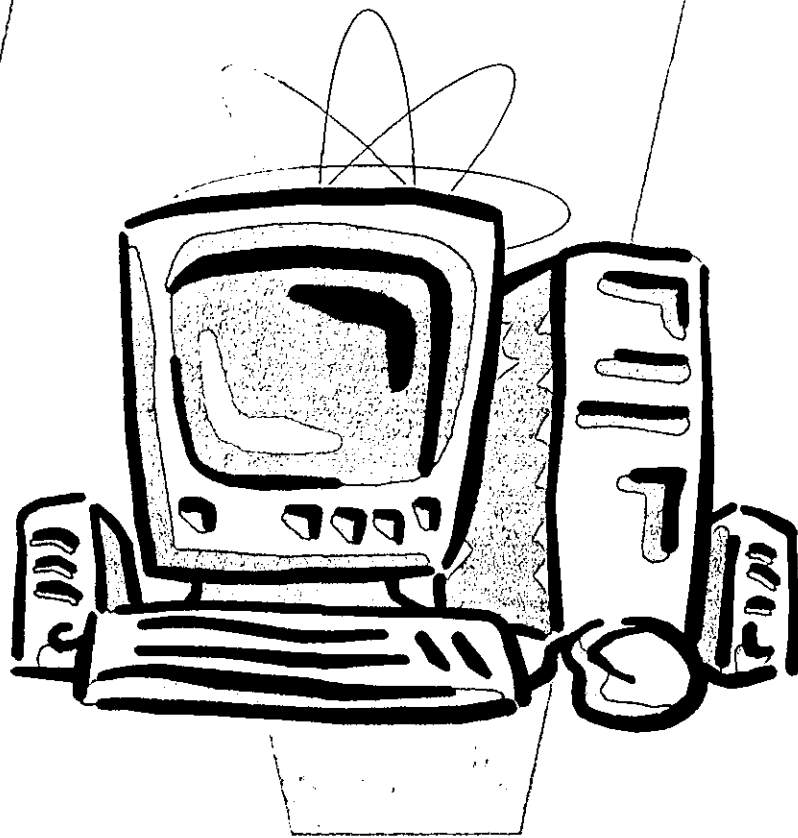

***Engaged Learning
in a Secondary
Science Classroom***

**Holly Rubach
UHON 499**

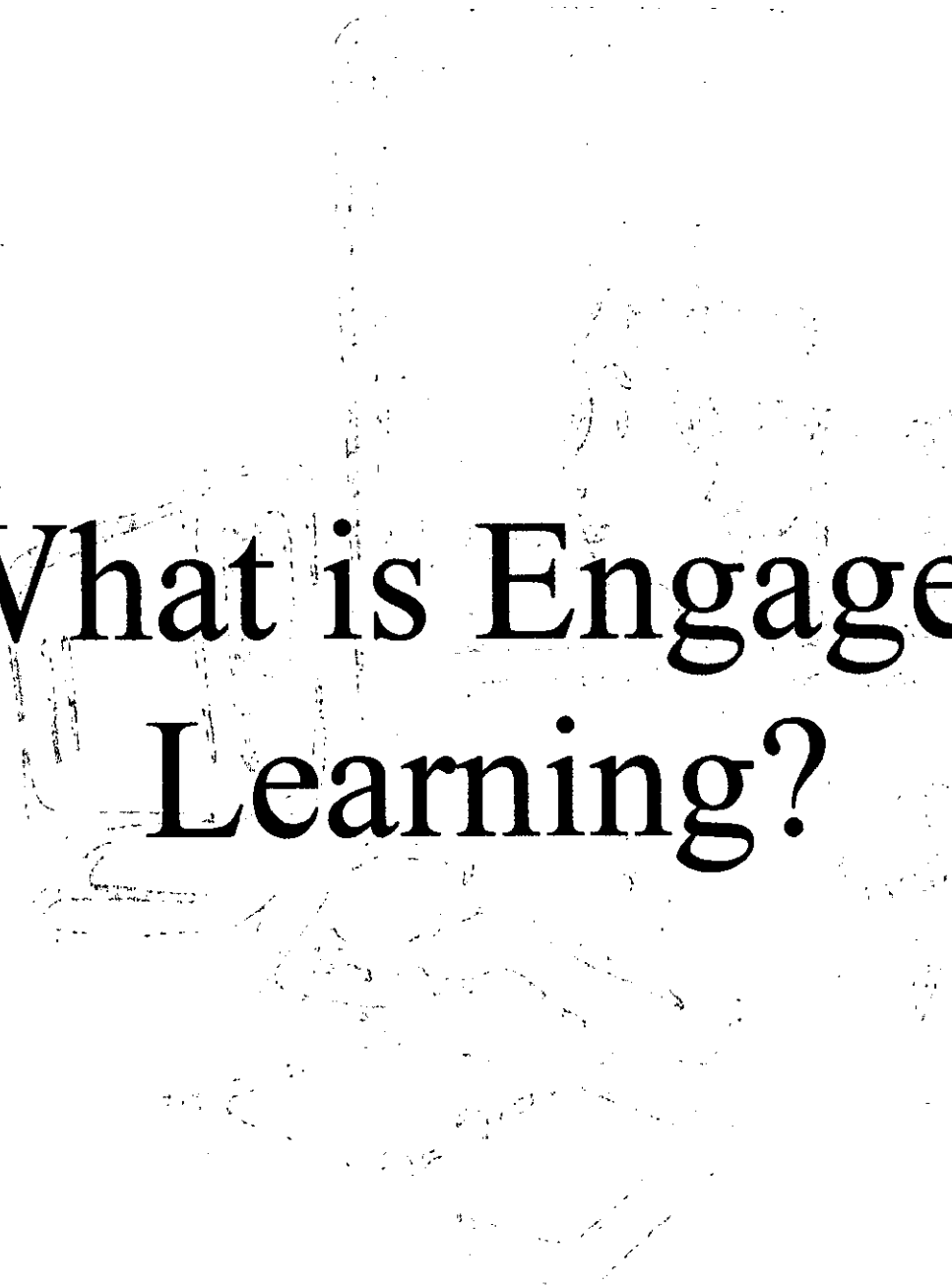

What is Engaged Learning?

What is Engaged Learning?

Engaged Learning seems to be the new buzzword in education. Many schools are trying to get their faculty to embrace this new philosophy. Engaged learning is a shift from traditional definitions of learning; it is a form of learning in which the students are focused on a challenging, real-life task. The task is student-directed and highly collaborative. However, engaged learning is more than just an interesting and fun activity for students to do; it is more than just group activities. Engaged learning puts the student in the driver's seat and requires the teacher to shift roles. The teacher is now the facilitator of learning rather than a dictator in the learning process.

Furthermore, engaged learning typically includes the integration of high-performance technology. All students have easy access to computers, and those computers have a variety of software (word processors, databases, spreadsheets, context-specific tools, etc.) and a variety of peripheral devices (video camera, television, scanner, videodisc player, etc.).

The products of engaged learning are students that take an active role in meaningful tasks and activities. They assume increasing responsibility for their own learning and demonstrate their understanding. They explore a variety of resources and strive for deep understanding through experiences that directly apply to their lives, promote curiosity and inquiry and stimulate new interests.

The characteristics of engaged learning are listed in detail in a following section entitled *Indicators of Engaged Learning*. Teachers can use these indicators to develop an engaged learning environment. In addition, the North Central Regional Educational Laboratory has created a web site that can help teachers compare their current instructional practices with a set of indicators for engaged learning and high-performance technology (www.ncrtec.org/capacity/profile/profwww.htm). With these tools teachers can assess their present teaching routine and begin to establish a high quality learning environment.

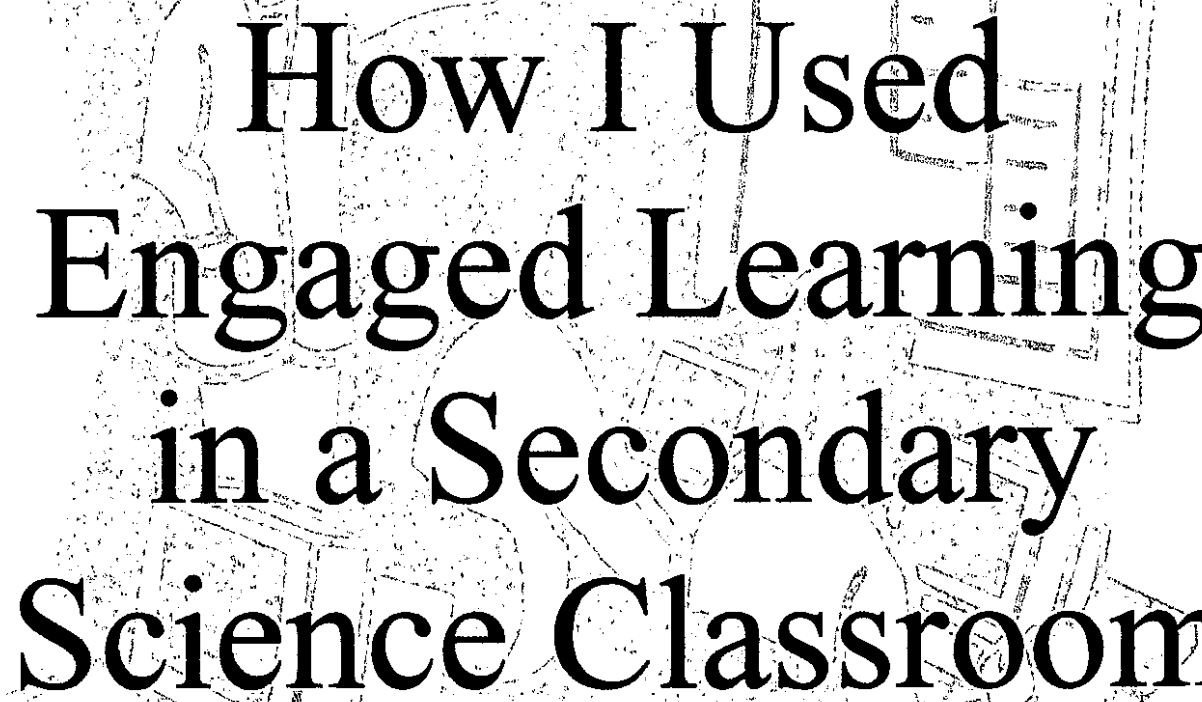

How I Used Engaged Learning in a Secondary Science Classroom

How I Used Engaged Learning in a Secondary Science Classroom

Engaged learning seemed to me a logical approach to improving the quality of education for young adults. This philosophy sounded like it would provide the students with applicable problem solving skills while motivating them and give the students ownership in their learning. My idea was to implement the characteristics of engaged learning into a secondary science classroom. For this task I chose the eighth grade physical science class at Unity Point School in Carbondale, Illinois. The unit plan that I developed discussed light and was taught during my student teaching semester in the spring of 2000.

In order for me to create a unit that supported engaged learning I had to consider the following indicators: vision of engaged learning, tasks for engaged learning, assessment of engaged learning, instructional models and strategies for engaged learning, learning context of engaged learning, grouping for engaged learning, teacher roles for engaged learning, student roles for engaged learning, and high performance technology.

When I asked what my engaged learning classroom would look like, I envisioned successful, engaged learners responsible for their own learning. In Lesson 7 I introduced the reflectivity of light; the students completed an experiment that identified the relationship between the color of an object and its reflectivity. The next day, Lesson 8, the students were to design an experiment to test the reflectivity of various earthen materials and then make a conclusion about the Earth's reflectivity. They were responsible for their own learning and making the connection between a concept and its practical application.

These two lessons also illustrate tasks and assessment for engaged learning. The students had to stretch their thinking and social skills in order to be successful. They had to communicate with their group members to develop a hypothesis and then test it. Also, the task was authentic; the concept the students learning in Lesson 7 was then applied to a

real-world situation. Then, the students were evaluated on how they chose to test their hypothesis and what they concluded from the testing.

When considering instructional model and strategies for engaged learning, I had to encourage the students to teach each other. This allows for co-construction of knowledge, which promotes engaged learning that is problem-, project-, and goal-based. A common strategy that I had the students use in Lesson 8 was brainstorming. The students had to brainstorm possible hypothesis and then ways to test their hypothesis.

Next, to facilitate a collaborative learning context I had to consider the grouping of the students. The students had already been placed into heterogeneous groups of four. All of the groups had a pretty even mixture of males and females, cultures, learning styles, abilities and socioeconomic status. Moreover, I was able to move students around to form new groups based on common interests or needs.

The last two indicators that I had to take into account were the student and teacher roles. During the unit I had to become a facilitator and a guide. My job was not to just provide information, but rather, to provide a rich environment for learning experiences needed for collaborative study. I became a mediator, model, and coach; consequently, the students became explorers. They were allowed to discover concepts and apply skills. The students were then encouraged to reflect upon their discoveries.

Lastly, I had to incorporate technology into the unit. I used a number of resources and tools. For example, videodiscs were used to introduce a new topic at the beginning of class. More exciting than the videodiscs was the CBL (computer based learning) equipment. Probes, like the light sensor we used in some of the lessons, allow the students to make various measurements. The probes are hooked up to either TI Calculator or a computer where the data is displayed. The students are not only being exposed to technology but they are also learning a new concept and developing skills that they will use later in their academic career.

Finally, when I completed my unit plan I used North Central Regional Educational Laboratory's online *Learning With Technology Profile Tool*. This website helped me compare the instructional practices in my unit plan with a set of indicators for engaged learning and high-performance technology. There are several categories, and for each category, there is a description of the indicators and examples that fall along a

continuum. There are three examples for each indicator. I then selected the example that best described my instructional practice. To illustrate, the following category with examples was used on the profile tool.

Knowledge Building

Learning is made public so that the learner can get input from diverse perspectives and build on that knowledge.

- Students work individually to do the best they can. Sharing information and resources may be considered “cheating.”
- Students periodically work in groups. Competition across groups is valued and encouraged.
- Students are provided many opportunities within the course of their work on an assignment to gather information and feedback from multiple sources including libraries, museums, colleges, other community information sources as well as other students, community members, experts, etc.

In this particular category I was able to select the third example because I gave my students many opportunities to collect information from various sources.

When an example had been chosen for all of the categories I was able to graph my responses. The following page is a print out of that graph. It shows categories that are high or low indicators of engaged learning and high-performance technology. A detailed description of these categories, known as indicators of engaged learning, can be found in the following section of this paper. My graph demonstrates that the unit plan I taught was moderately well developed for engaged learning and very well developed for including high-performance technology. In the future, I could use this tool to identify the areas I need to focus on to construct an engaged learning environment.

In conclusion, I found that my hypothesis that engaged learning would provide the students with applicable problem solving skills while motivating them and give the students ownership in their learning could be accepted. The students enjoyed this unit and performed well on a written test over the subject matter. A performance evaluation

would have been a better assessment tool with regards to engaged learning; perhaps the *Science Sleuths* activity in Lesson 9 would have done a good job that. However, I was limited in what I could do because I was student teaching in someone else's class. In the future, I think that it would be interesting to investigate whether engaged learning, like other methods of instruction, becomes tedious over time and repeated exposure.



Learning With Technology Profile Tool Results

Name: Engaged Learning and Technology in a Secondary Science Classroom
Date: May 10, 2000

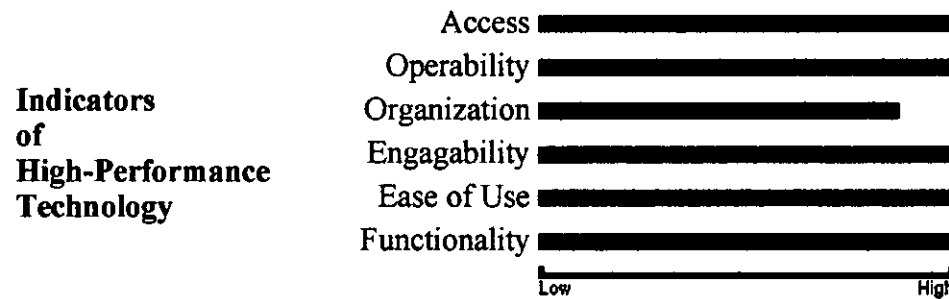
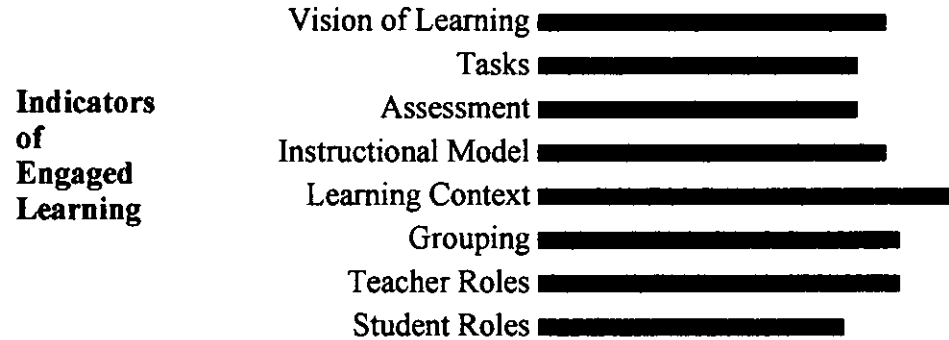

[NCRTEC home page](#)

North Central Regional Technology in Education Consortium/ ncrttec@ncrel.org
Copyright (c); 1997 North Central Regional Educational Laboratory. All rights reserved.

Indicators of Engaged Learning

Vision of Engaged Learning
Tasks for Engaged Learning
Assessment of Engaged Learning
Instructional Models and Strategies for Engaged Learning
Learning Context of Engaged Learning
Grouping for Engaged Learning
Teacher Roles for Engaged Learning
Student Roles for Engaged Learning

In recent years, researchers have formed a strong consensus on the importance of engaged learning in schools and classrooms. This consensus, together with a recognition of the changing needs of the 21st century, has stimulated the development of specific indicators of engaged learning. Jones, Valdez, Nowakowski, and Rasmussen (1994) developed the indicators described on the following pages. These indicators of engaged learning can act as a "compass" for reform instruction, helping educators chart an instructional course and maintain an orientation based on a vision of engaged learning and what it looks like in the classroom and community.

www.ncrel.org

Vision of Engaged Learning

- *Responsible for Learning.* Students take charge of their own learning and are self-regulated. They define learning goals and problems that are meaningful to them; understand how specific activities relate to those goals; and, using standards of excellence, evaluate how well they have achieved the goals. Successful, engaged learners also have explicit measures and criteria for assessing their work as well as benchmark activities, products, or events for checking their progress toward achieving their goals.
- *Energized by Learning.* Engaged learners find excitement and pleasure in learning. They possess a lifelong passion for solving problems and understanding ideas or concepts. To such students, learning is intrinsically motivating.
- *Strategic.* Engaged learners continually develop and refine learning and problem-solving strategies. This capacity for learning how to learn includes constructing effective mental models of knowledge and resources, even though the models may be based on complex and changing information. Engaged learners can apply and transfer knowledge in order to solve problems creatively and they can make connections at different levels.
- *Collaborative.* Engaged learners understand that learning is social. They are able to see themselves and ideas as others see them, can articulate their ideas to others, have empathy for others, and are fair-minded in dealing with contradictory or conflicting views. They have the ability to identify the strengths and intelligences of themselves and others.

Tasks for Engaged Learning

- *Challenging.* Unlike tasks usually offered in schools, challenging tasks are typically complex and required sustained amounts of time. Such tasks also require students to stretch their thinking and social skills in order to be successful.
- *Authentic.* Authentic tasks correspond to tasks in the home and workplace. They are closely related to real-world problems and projects, build on life experiences, require in-depth work, and benefit from frequent collaboration. Such collaboration can take place with peers and mentors within school or with diverse people outside of school.
- *Integrative/interdisciplinary.* Challenging and authentic tasks often require integrated instruction, which blends disciplines into thematic or problem-based pursuits, and instruction that incorporates problem-based learning and curriculum by project.

Assessment of Engaged Learning

- *Performance-Based.* Students construct knowledge and create artifacts to represent their learning. Ideally, students also are involved in generating performance criteria and are instrumental in the overall design, evaluation, and reporting of their assessment.
- *Generative.* The overriding purpose of assessment is to improve learning. To that end, assessment should closely match the goals of the curriculum; represent significant knowledge and enduring skills, content, and themes; and provide authentic contexts for performance. The performance criteria should be clear, well articulated, and part of the students' learning experience prior to assessment. Indeed, developing standards of excellence for learning and thinking is an important part of learning.
- *Interwoven with Curriculum and Instruction.* Assessment should include all meaningful aspects of performance. It should encompass the evaluation of individual as well as group efforts; self-, peer, and teacher assessments; attitudes and thinking processes; drafts or artifacts of developing products as well as final products; open-ended as well as structured tasks; and tasks that emphasize connections, communication, and real-world applications. Multiple measures (e.g., surveys, inventories, journals, illustrations, oral presentations, demonstrations, models, portfolios, and other artifacts of learning) are needed to assess "big ideas" and complex learning outcomes over time.
- *Equitable Standards.* Parents and students should be familiar with the standards that apply to all students and be able to evaluate the performance of an individual or group using those standards.

Instructional Models and Strategies for Engaged Learning

- *Interactive.* Instruction actively engages the learner.
- *Generative.* Generative instruction encourages learners to construct and produce knowledge in meaningful ways by providing experiences and learning environments that promote deep, engaged learning. Generative instruction also encourages learners to solve problems actively, conduct meaningful inquiry, engage in reflection, and build a repertoire of effective strategies for learning in diverse social contexts.

Learning Context for Engaged Learning

- *Knowledge-Building Learning Community.* The learning community resists fragmentation and competition and enables students to learn more collaboratively.
- *Collaborative.* In learning communities, intelligence is assumed to be distributed among all members. Collaborative classrooms, schools, and communities encourage all students to ask hard questions; define problems; take charge of the conversation when appropriate; participate in assessments and in setting goals, standards, and benchmarks; have work-related conversations with various adults in and outside school; and engage in entrepreneurial activities.
- *Empathetic.* Learning communities search for strategies to build on the strengths of all members. These strategies are especially important for learning situations in which members have very different prior knowledge.

Grouping for Engaged Learning

- *Heterogeneous.* Heterogeneous groups include males and females and a mix of cultures, learning styles, abilities, socioeconomic status, and ages. This mixture brings a wealth of background knowledge and differing perspectives to authentic, challenging tasks.
- *Flexible.* Flexible groups are configured and reconfigured according to the purposes of instruction. This flexibility enables educators to make frequent use of heterogeneous groups and to form groups, usually for short periods of time, based on common interests or needs.
- *Equitable.* The use of both flexible and heterogeneous groups is one of the most equitable means of grouping. It ensures increased opportunities to learn for all students.

Teacher Roles for Engaged Learning

- *Facilitator.* The teacher provides rich environments, experiences, and activities for learning by incorporating opportunities for collaborative work, problem solving, authentic tasks, and shared knowledge and responsibility.
- *Guide.* In a collaborative classroom, the teacher must act as a guide - a complex and varied role that incorporates mediation, modeling, and coaching. When mediating student learning, the teacher frequently adjusts the level of information and support based on students' needs and helps students to link new information to prior knowledge, refine their problem-solving strategies, and learn how to learn.
- *Co-Learner and Co-Investigator.* Teachers and students participate in investigations with practicing professionals. Using this model, students explore new frontiers and become producers of knowledge in knowledge-building communities. Indeed, with the help of technology, students may become the teachers as teachers become the learners.

Student Roles for Engaged Learning

- *Explorer.* Students discover concepts and connections and apply skills by interacting with the physical world, materials, technology, and other people. Such discovery-oriented exploration provides students with opportunities to make decisions while figuring out the components/attributes of events, objects, people, or concepts.
- *Cognitive Apprentice.* Students become cognitive apprentices when they observe, apply, and refine through practice the thinking processes used by real-world practitioners. In this model, students reflect on their practice in diverse situations and across a range of tasks, and they articulate the common elements of their experiences.
- *Producers of Knowledge.* Students generate products for themselves and their community that synthesize and integrate knowledge and skills. Through the use of technology, students increasingly are able to make significant contributions to the world's knowledge.

Unit Plan: Light



Eighth Grade
Physical Science
10 Day Unit
Holly Rubach

8th Grade – Physical Science

Ryne and John use the CBL system with light sensor to determine the effect distance has on light intensity.

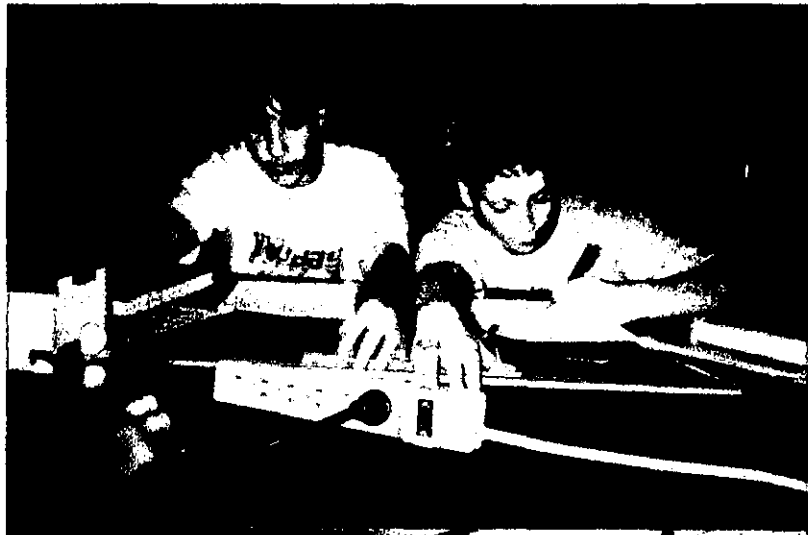

Michael tries to determine the color of various pieces of paper while looking through colored cellophane; he is learning about how light is absorbed and reflected.

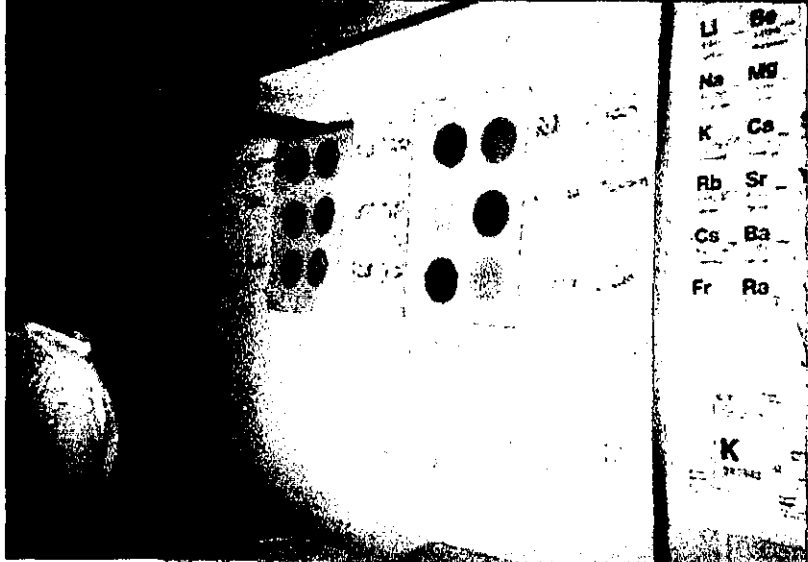

The students use the CBL system with a force sensor to determine the mechanical advantage of first, second, and third class levers.



Table of Contents

1. Significance of the Unit
2. Objectives
3. Materials and Resources
4. Teacher Responsibility
5. Lesson Plans
 - Lesson 1: The Electromagnetic Spectrum
 - Lesson 2: The Applications of Light
 - Lesson 3: How Bright is the Light
 - Lesson 4: Light and Color
 - Lesson 5: Reflection
 - Lesson 6: Reflectivity of Light
 - Lesson 7: Applying Reflectivity of Light
 - Lesson 8: Polarized Light
 - Lesson 9: Unit Review
 - Lesson 10: Summation and Evaluation
6. Evaluation
7. Calendar of Activities

Significance of the Unit

The general objective of this unit is to develop an understanding of the properties of light. This unit plan covers *Chapter 19: Light* on pages 526 – 555 in the student's textbook Physical Science. The experiments selected for this unit align with the objectives in Chapter 19. The textbook will be used as a supplementary resource to help define terms and clarify ideas that we will encounter in our experiments.

Objectives

1. Contrast electromagnetic waves with other kinds of waves.
2. Describe the arrangement of electromagnetic waves on the electromagnetic spectrum.
3. Explain at least one application of each type of electromagnetic wave.
4. Describe the differences among opaque, transparent, and translucent materials.
5. Explain how you see color.
6. Describe the difference between light color and pigment color.
7. Explain how incandescent and fluorescent bulbs work.
8. Analyze the advantages and disadvantages of different light sources.
9. State and give examples of the law of reflection.
10. Clarify the correlation between different colors and materials and their reflectivity.
11. Explain how refraction is used to separate white light into colors of the spectrum.
12. Describe how diffraction and interference patterns demonstrate the wave behavior of light.
13. Describe polarized light and the uses of polarizing filters.

Materials and Resources

The materials needed for each lesson are listed below.

Lesson 1: The Electromagnetic Spectrum

Materials: diffraction grating slide, PVC pipe, masking tape, knife, aluminum foil, various light sources (incandescent, carbon, filament, neon, fluorescent, plant, blue, and yellow), Diffraction Lab sheet, Diffraction Data sheet, Physics for Fun: Light Unit Video, *Battle of the Bulbs* Reinforcement Worksheet, and *Battle of the Bulbs* Study Guide Worksheet

Lesson 2: The Applications of Light

Materials: The Hole Story (video about ozone depletion), Physics for Fun: Light video

Lesson 3: How Bright is the Light

Materials: Macintosh or IBM-compatible computer, Serial Box Interface or ULI, Data Logger, Vernier Light Sensor, meter stick, lamp with 100-watt bulb, masking tape, shoebox

Lesson 4: Light and Color

Materials: colored paper, colored cellophane, slides of primary colors of light, large square of tin foil, large square of wax paper, large square of saran wrap, large square of wax paper, primary pigment paints, mixing tray for paints

Lesson 5: Reflection

Materials: each group should be provided with the following supplies: a copy of the lab *Mirrors and Rays of Light*, thick chalkboard (1 sheet), unlined paper (1 sheet), mirror support, straight pins (2), plane mirror, cellophane tape, meter stick, protractor, a copy of the reinforcement worksheet *Wave Properties of Light*, and a copy of the study guide worksheet *Wave Properties of Light*

Lesson 6: Reflectivity of Light

Materials: Macintosh or IBM-compatible computer, Serial Box Interface or ULI, Data Logger, Vernier Light Sensor, ring stand, utility clamp, white paper, black paper, 2 other pieces of colored paper, aluminum foil, *Reflectivity of Light* experiment sheet, Physics for Fun: Light video

Lesson 7: Applying Reflectivity of Light

Materials: Macintosh or IBM-compatible computer, Serial Box Interface or ULI, Data Logger, Vernier Light Sensor, ring stand, utility clamp, sand, soil, water, and other materials, aluminum foil, modified (Applying) *Reflectivity of Light* experiment sheet

Lesson 8: Polarized Light

Materials: Macintosh or IBM-compatible computer, Serial Box Interface or ULI, Data Logger, Vernier Light Sensor, ring stand, utility clamp, 2 Polaroid filters, *Polaroid Filters* experiment sheet, *Physical Science* video disc

Lesson 9: Unit Review

Materials: Science Discovery: Science Sleuths videodisc and resource manual, transparency with the questions and answers to the textbook's chapter review, transparency of rubric for Light Unit Exam, and for each student, a copy of the chapter review worksheets and a copy of the *Science Sleuths Lab Report*

Lesson 10: Summation and Evaluation

Materials: For each student, a copy of the exam provided by the publisher of the text, Physical Science.

The following is a list of resources that I used to created this unit plan.

Blecha, Milo K., and Raymond O'Toole. Activities for Exploring Matter and Energy. Irvine, California: Laidlaw Brothers, 1980.

Brock, Ellen, Kristina Johnson, and Carol McLaren. Physics for Fun: Light Unit. Longmont, Colorado: Sopris West, 1993.

Johnson, Gordon P., Bonnie B. Barr, and Michael B. Leyden. Physical Science. Menlo Park, California: Addison Wesley, 1988.

Maton, Anthea., et al. Exploring Physical Science. Englewood Cliffs, New Jersey: Prentice Hall, 1995.

McLaughlin, Charles W. and Marilyn Thompson. Physical Science: Assessment – Chapter and Unit Tests. New York: Glencoe/McGraw-Hill, 1997.

McLaughlin, Charles W. and Marilyn Thompson. Physical Science: Chapter Review. New York: Glencoe/McGraw-Hill, 1997.

McLaughlin, Charles W. and Marilyn Thompson. Physical Science: Critical Thinking/Problem Solving. New York: Glencoe/McGraw-Hill, 1997.

McLaughlin, Charles W. and Marilyn Thompson. Physical Science: Reinforcement – Teacher Edition. New York: Glencoe/McGraw-Hill, 1997.

McLaughlin, Charles W. and Marilyn Thompson. Physical Science: Study Guide – Teacher Edition. New York: Glencoe/McGraw-Hill, 1997.

McLaughlin, Charles W. and Marilyn Thompson. Physical Science: Teachers Wraparound Edition. New York: Glencoe/McGraw-Hill, 1997.

Nolan, Louise M. Physical Science: Teacher's Edition. Lexington, Massachusetts: Heath, 1987.

Videodiscovery. Science Discovery: Science Sleuths. United States: Holt Rinehart and Winston, 1993.

Videodiscovery. Sleuth Resource Guidebook. Seattle: Holt Rinehart and Winston, 1994.

Teacher Responsibilities

The teacher will be responsible for getting all of the materials together for each experiment. Copies of the handouts are to be made in advance and ready to distribute to the students. The teacher is responsible for grading and returning papers to the students.

The Electromagnetic Spectrum

Holly Rubach
Eighth Grade
Physical Science
03-03-00
10:25 a.m. – 11:10 a.m.

Materials: diffraction grating slide, PVC pipe, masking tape, knife, aluminum foil, various light sources (incandescent, carbon, filament, neon, fluorescent, plant, blue, and yellow), Diffraction Lab sheet, Diffraction Data sheet, Physics for Fun: Light Unit Video, *Battle of the Bulbs* Reinforcement Worksheet, and *Battle of the Bulbs* Study Guide Worksheet

Estimated Time: 45 minutes

State Goals: As a result of this lesson, students will have a working knowledge of the processes, techniques, methods, equipment, and available technology of science.

Lesson Objective: To observe the diffraction of light through a diffraction grating and compare the diffraction spectrum produced by various light sources.

Introduction: Today we are going to explore the spectrum that makes up various light sources. Two kind of commonly used lighting are incandescent and fluorescent. Incandescent light is produced by a thin tungsten wire, or filament, that is heated in an incandescent bulb until it glows. Fluorescent light is produced when ultraviolet radiation inside a fluorescent light bulb causes its fluorescent coating to glow; fluorescent lights use less energy than incandescent lights. White light is a combination of many different wavelengths all along the visible light spectrum. White light can be separated into its many colors by using a diffraction grating. A diffraction grating is a piece of glass or plastic made up of many parallel slits. Diffraction gratings commonly have as many as 12 000 slits per centimeter. When white light shines through a diffraction grating, the colors separate. Reflective materials can be ruled with closely spaced grooves to produce diffraction patterns. For example, you can see the dazzling results of simple diffraction grating by looking at the reflection of light from the microscopic recording pits in compact discs.

Focusing Event: <Show Topic 7: Dispersion on the Video Physics for Fun: Light Unit.> Ask the students to hypothesize about the differences of various light sources. Are they all the same? What are some characteristics that make them different from one another? <Refer to *Figure 19-22* on page 548 of the text.> Which colors of the visible spectrum have the highest frequency? The highest energy? <Refer to *Figure 19-2* on page 529 of the text.> <Have the students read the sections *Battle of the Bulbs* on pages 544 and 545 and paragraph two about diffraction grating on page 550 of their textbook.>

Electromagnetic Spectrum

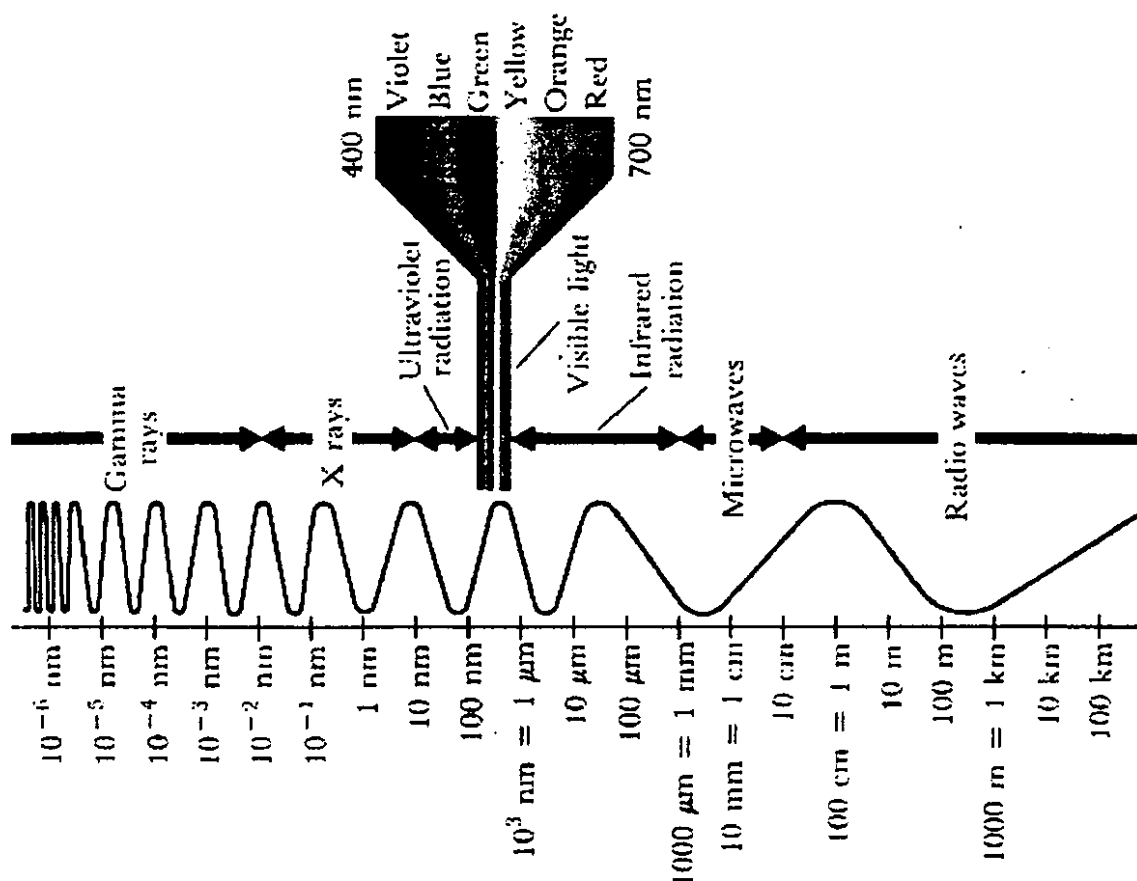

Instructional Procedures: <Handout experiment and data sheet to class.> Have all of the materials needed for each group at the center of each table. Read the purpose and procedures to the students. The students will work with the people at their table in groups of two. Have students look at *Figure 1* on the experiment sheet to help with set up. Also, have various light sources set up in the center of each table as stations. The students will rotate from station to station making observations of the various light sources. Make sure students remain on task, and monitor the quality of their work.

Guided Practice: The lab we are performing today is the guided practice. By looking at the answers I will be able to see if they understand the concept of the lab. If the students are off track, I will help them understand with cues and questioning techniques.

Independent Practice: For homework the students are responsible for completing *Battle of the Bulbs* Reinforcement Worksheet and *Battle of the Bulbs* Study Guide Worksheet.

Closure: Today, we explored the visible portion of the electromagnetic spectrum. We used a diffraction grating to separate light from various sources into the colors that they were composed of. Can someone explain to me what a diffraction grating is? (A piece of glass or

plastic made up of many parallel slits. Most diffraction gratings have as many as 12 000 slits per centimeter.) What is the diffraction grating responsible for doing? (When white light shines through a diffraction grating, the colors separate.) How does the spectrum of light from the various sources we looked at today differ? (Answers will vary.) What happens when the diffraction grating is repositioned so that its lines are perpendicular to the slit in the foil? (The spectra changes shape from having rectangular shape with thick bands of color to a thin, thread-like shape with the same color bands.) What is an example of diffraction gratings that we encounter everyday? (You can see the reflection of light from the microscopic recording pits in compact discs.) Compare the spectra from a white light that is at its brightest setting to the spectra at its dimmest setting. (When a white light is at its brightest, it should have all of the colors present. At its dimmest, a light will create spectra that should show mostly red frequencies.) What is the reasoning for the previous response? (The brighter a light source is, the more higher-frequency colors, such as blue and violet, will be present.)

Evaluation: The following factors will be considered to determine if the objective of this lesson plan was met: quality and accuracy of observations on Diffraction Data Sheet and correctness of the questions answered on the *Battle of the Bulbs* Reinforcement and Study Guide worksheets. The following rubric will be used to grade the assignment:

Section	Number of Questions	Point Value Per Question	Total Possible Points
Diffraction Data Sheet	7	3	21
<i>Battle of the Bulbs</i> Reinforcement Worksheets	2	5	10
<i>Battle of the Bulbs</i> Study Guide Worksheets	12	2	24
Total			55

Note: Short answer questions may be given partial credit. The total number of points possible for these three assignments is 55; however, they will be graded out of 50. Thus, there will be the opportunity to earn 5 extra credit points.

Grading Scale

A = 50-46 B = 45-43 C = 42-38 D = 37-35 F = 34 and below

Video Snapshots

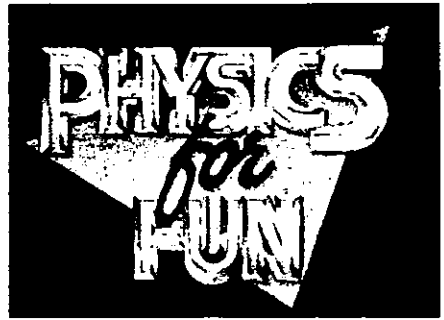

A color wheel spins so fast that it looks white.

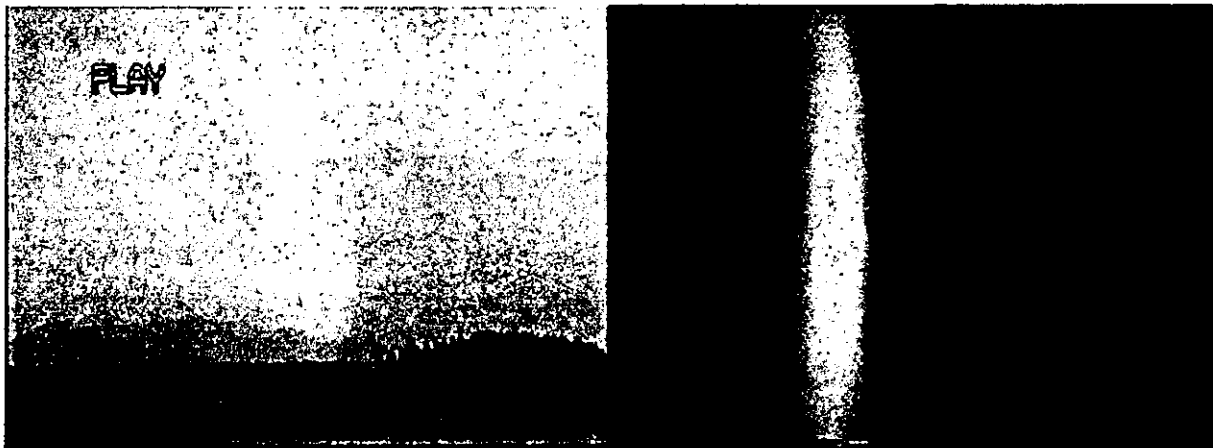

A rainbow is white light broken into its component colors, or “dispersed.”

Prisms show us that we can break up light according to its wavelengths.

Video Snapshots

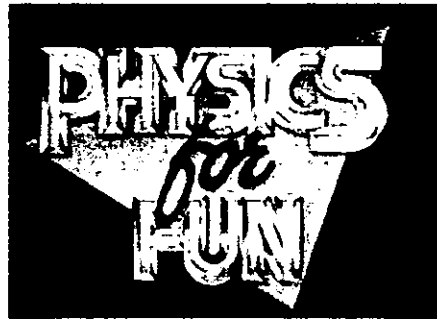

Professor Johns lets us witness absorption of light energy by breaking a colored balloon with a laser. A red balloon absorbs the green light from a laser, heats up, and pops.



Professor Johnson recreates and explains the conditions which make sunsets red and the sky blue. This interaction of light's different energies is called scattering. Absorption of different wavelengths of light lets us see different colors.

Diffraction

Purpose

The purpose of this experiment is to:

- observe the diffraction of light through a diffraction grating
- compare the diffraction spectrum produced by various light sources

Materials

diffraction grating slide
masking tape
aluminum foil

PVC pipe
knife
various light sources (incandescent, carbon,
filament, neon, fluorescent, plant, blue, and yellow)

Procedure

1. Obtain a section of piping similar to the one shown below.
2. Cut a piece of aluminum foil large enough to cover one of the ends of the tube.
3. Using a knife, cut a small slit in the foil.
4. Place the foil over one of the tube's ends, and position the foil so that the slit is in the center of the tubing.
5. Tape the piece of foil to the tube.
6. Hold the diffraction grating slide up to the end of the tube opposite the foil.
7. Position the grating so that the lines in the grating are parallel to the slit in the foil.
8. Looking through the diffraction grating end of the tube, observe the light from one of the light sources. Record your observations on the data sheet.
9. In the same manner, observe light from the remaining light sources. Record your observations on the data sheet.
10. Change the position of the grating so that the lines in the grating are perpendicular to the slit in the foil.
11. Once again, looking through the diffraction grating end of the tube, observe the light from the various light sources. Record your observations.

Questions

1. How does the spectrum of light from the various sources differ?

2. What happens when the diffraction grating is repositioned so that its lines are perpendicular to the slit in the foil?

3. What changes did you notice when you rotated the diffraction grating?

Name _____ Section _____ Date _____

Diffraction Data

Incandescent

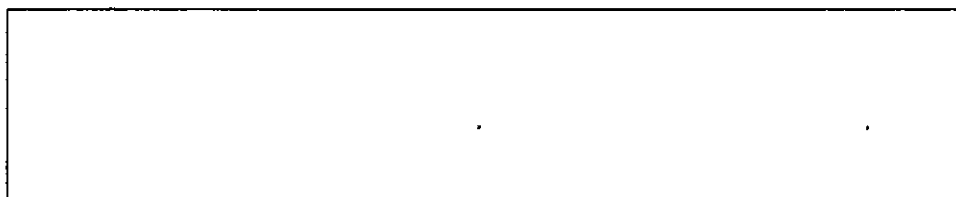

Carbon Filament

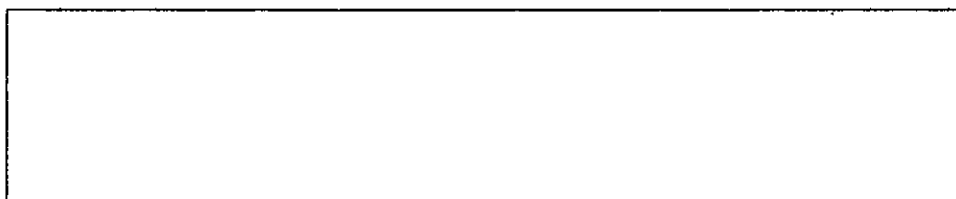

Neon

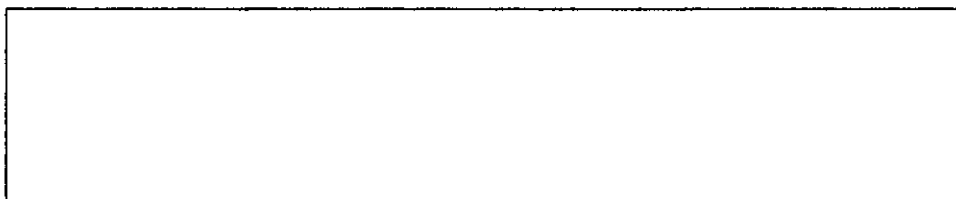

Fluorescent

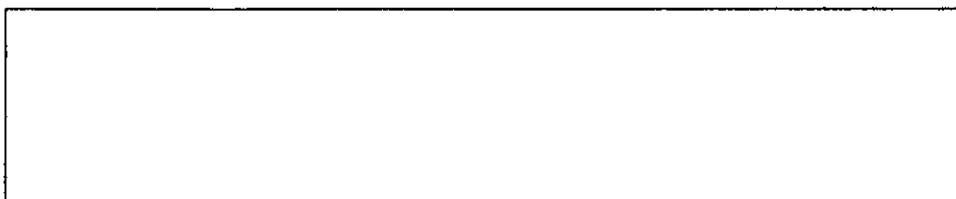

Plant Light

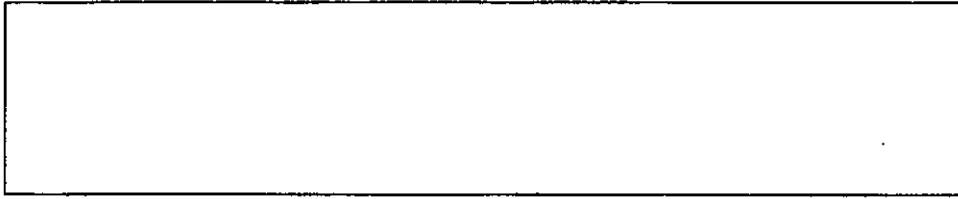

Blue Light



Yellow Light



Name Key Section _____ Date _____

Diffraction Data

Incandescent

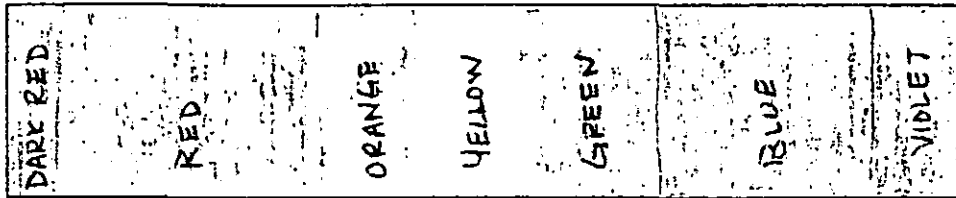

Carbon Filament

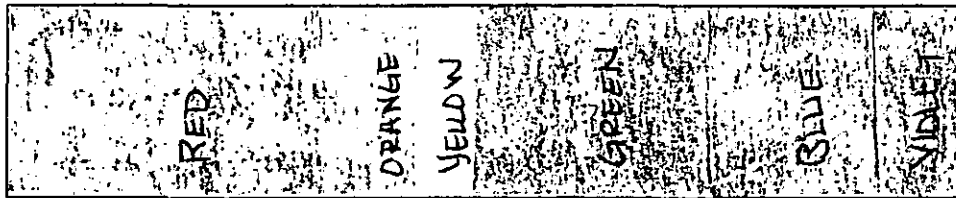

Neon

Very Dim
↙ ↘

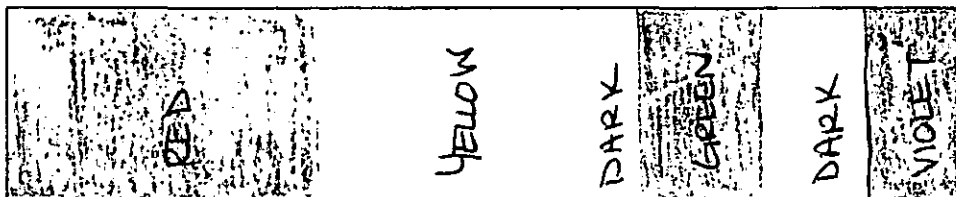

Fluorescent

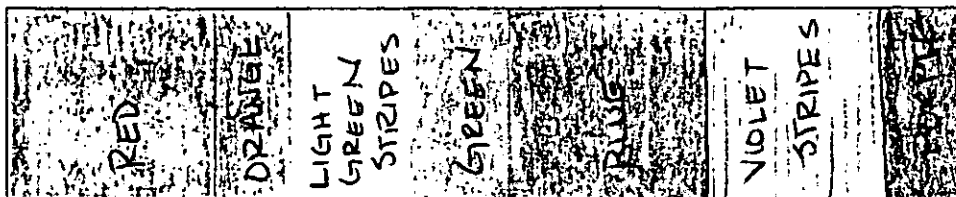

Plant Light

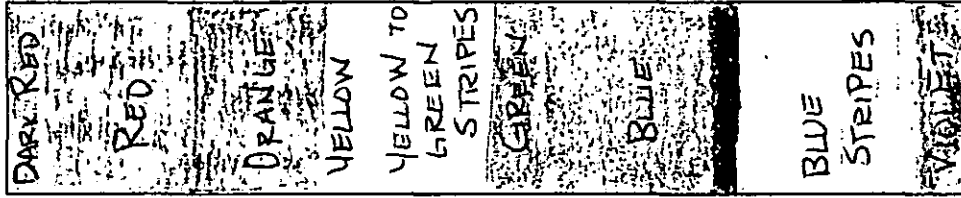

Blue Light

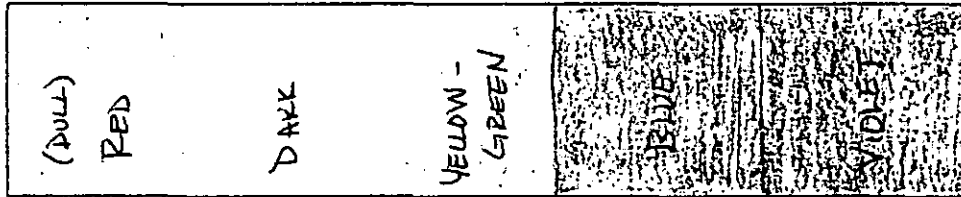

Yellow Light

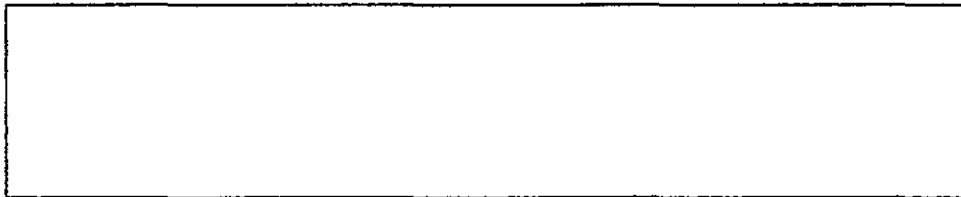
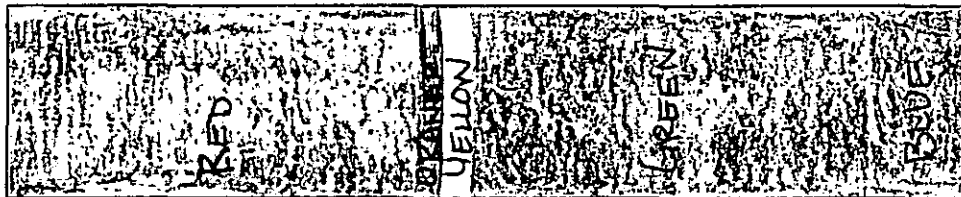

Chapter 19

STUDY GUIDE

Use with Text Pages 544-545

● Battle of the Bulbs

Determine whether the italicized term makes each statement true or false. If the statement is true, write the word "true" in the blank. If the statement is false, write in the blank the term that makes the statement true.

- _____ 1. Incandescent light is produced by *heat*.
- _____ 2. An incandescent bulb contains a filament of *platinum*.
- _____ 3. *Infrared* radiation causes phosphorus to give off visible light.
- _____ 4. A fluorescent light uses *5 times* as much energy as an incandescent bulb.
- _____ 5. A fluorescent bulb is filled with gas at a *high* pressure.
- _____ 6. *Less than half* of the energy given off by incandescent bulbs is heat.
- _____ 7. The inner wall of a fluorescent bulb is coated with *potassium*.
- _____ 8. About *10 percent* of all electricity consumed in the United States is used for lighting.
- _____ 9. When the filament in an incandescent lamp gets hot, it gives off *ultraviolet radiation*.
- _____ 10. A fluorescent bulb is *more* efficient than an incandescent bulb.
- _____ 11. An incandescent bulb contains a thin wire called a *filament*.
- _____ 12. In a fluorescent bulb, phosphorus *reflects* ultraviolet radiation.

Chapter 19

Use with Text Pages 544-545

STUDY GUIDE

● Battle of the Bulbs

Determine whether the italicized term makes each statement true or false. If the statement is true, write the word "true" in the blank. If the statement is false, write in the blank the term that makes the statement true.

TRUE1. Incandescent light is produced by *heat*.TUNGSTEN2. An incandescent bulb contains a filament of *platinum*.ULTRAVIOLET3. *Infrared* radiation causes phosphorus to give off visible light.1154. A fluorescent light uses *5 times* as much energy as an incandescent bulb.LOW5. A fluorescent bulb is filled with gas at a *high* pressure.MORE6. *Less than half* of the energy given off by incandescent bulbs is heat.PHOSPHOROUS7. The inner wall of a fluorescent bulb is coated with *potassium*.20 PERCENT8. About *10 percent* of all electricity consumed in the United States is used for lighting.LIGHT9. When the filament in an incandescent lamp gets hot, it gives off *ultraviolet radiation*.TRUE10. A fluorescent bulb is *more* efficient than an incandescent bulb.TRUE11. An incandescent bulb contains a thin wire called a *filament*.ABSORBS12. In a fluorescent bulb, phosphorus *reflects* ultraviolet radiation.

REINFORCEMENT

● Battle of the Bulbs

1. Write a paragraph about lighting. Use the words listed below in your paragraph.

light bulb
incandescent light
fluorescent light

tungsten
heat
filament

phosphorus
coating
ultraviolet radiation

light
efficiency

2. Observe incandescent and fluorescent lights in your home, in your school, and in a store or office.

a. Where is each type of light more likely to be used? _____

b. Compare and contrast the color and general appearance of fluorescent and incandescent lights. _____

c. Why do you think the types of lights were chosen for use in the places that you observed?

REINFORCEMENT

● Battle of the Bulbs

1. Write a paragraph about lighting. Use the words listed below in your paragraph.

light bulb
incandescent light
fluorescent light

tungsten
heat
filament

phosphorus
coating
ultraviolet radiation

light
efficiency

ACCEPT ALL REASONABLE PARAGRAPHS

2. Observe incandescent and fluorescent lights in your home, in your school, and in a store or office.

a. Where is each type of light more likely to be used? Fluorescent lights are more likely to be used in stores and offices. Incandescent lights are used more extensively in homes.

b. Compare and contrast the color and general appearance of fluorescent and incandescent lights. In general, incandescent lights give a more pleasant and warmer color of light than do fluorescent lights. However, some fluorescent lights have special colors and are more like incandescent lights. Depending on the size of the bulb, both types of bulbs can give out plenty of light.

- c. Why do you think the types of lights were chosen for use in the places that you observed?

For home use, the color of the incandescent bulb is softer and has a warmer feel. Also, most home lights are designed for incandescent bulbs. For business use, fluorescent lights are cooler and use far less energy. When a large number of fixtures are in use, the cost of lighting a facility becomes a major consideration.

The Applications of Light

Holly Rubach
Eighth Grade
Physical Science
03-06-00
10:25 a.m. – 11:10 a.m.

Materials: The Hole Story (video about ozone depletion), Physics for Fun: Light video

Estimated Time: 45 minutes

State Goals: As a result of this lesson, students will have a working knowledge of the processes, techniques, methods, equipment, and available technology of science.

Lesson Objective: To discover at least one application of each type of electromagnetic wave.

Introduction: The electromagnetic spectrum ranges from very long-wavelength, low-frequency radio waves to very short-wavelength, high-frequency gamma rays. The amount of energy carried by an electromagnetic wave increases with frequency. Only a very small region of the electromagnetic spectrum is visible. The electromagnetic spectrum covers a tremendous range of frequencies and wavelengths. Comparing the frequencies of radio waves to those of visible light is like comparing the thickness of this page to the Earth's distance from the sun! Because the differences are so great, the various regions of the spectrum are given different names.

Radio waves have the lowest frequencies and longest wavelengths. They are the waves used to transmit information from the antenna of a broadcasting station to the antenna on your radio or television. Radio waves are also used in medicine to create pictures of different parts of the human body. Magnetic resonance imaging causes different atoms in the body to vibrate, and by analyzing the response of different sections of the body to different frequencies, doctors can create pictures of parts of the human body without harming the cells. One particular group of radio waves, microwaves, is used to in microwave ovens to heat food in a short amount of time. Microwaves transfer energy to the water molecules inside the food, causing them to vibrate and rotate faster. As a result, the kinetic energy and temperature of the water molecules increase; thus, the food is "cooked". Microwaves are used for communication, too. They transmit information in cellular and portable telephones. Short-wavelength microwaves are used in radar (*radio detecting and ranging*). Radar is used to locate objects and monitor speed. A radar device operates by sending out short pulses of radio waves. Any object within a certain distance will reflect these waves, a receiver picks up the reflected waves, records the length of time it takes for the waves to return, and then calculates the distance to the object.

Infrared rays have frequencies slightly lower than those of visible light. Although infrared rays cannot be seen, they can be felt as heat. All objects give off infrared rays; however, warmer objects give off more infrared rays than cooler objects do. You can feel infrared rays as heat from a light bulb, a stove, or the sun. Cool objects can absorb the energy

from infrared waves and become hotter. For this reason, infrared lamps are used to keep food hot, relieve sore muscles, and dry paint and hair. Infrared cameras are devices that take pictures using heat instead of light. Such cameras allow pictures to be taken at night. Certain types of photographs that are taken using heat are called thermograms. Thermograms can identify the warm and cold areas of an object or person. They can be used to detect heat loss in a building, or they can be used in medicine to identify unhealthy tissue that becomes hotter than the surrounding healthy tissue. Tumors are sometimes detected in a thermogram because they are warmer than the healthy tissue around them.

Despite its small range, the visible spectrum is of great importance. Life on Earth could not exist without visible light. Nearly half the energy given off by the sun is in the form of visible light. Over billions of years, plants and animals have evolved in such ways as to be sensitive to the energy of the sun. Without such adaptations, life would be impossible. Visible light is essential for photosynthesis, the process by which green plants make food.

Electromagnetic waves with frequencies just higher than visible light are called ultraviolet rays. The energy of ultraviolet rays is great enough to kill living cells. Therefore, ultraviolet lamps are often used to kill germs in hospitals and to destroy bacteria and preserve food in processing plants. Although the eyes cannot see the ultraviolet rays present in sunlight, their effects can be felt as sunburn. When your body absorbs sunlight, ultraviolet rays cause your skin cells to produce vitamin D. Vitamin D is needed to make healthy bones and teeth. Despite this benefit, ultraviolet rays are harmful to body cells. (All electromagnetic waves beyond the visible region – ultraviolet, X rays, and gamma rays – are harmful to living cells.) Tanning is the body's way of protecting itself against these harmful rays, but overexposure to ultraviolet rays can cause serious damage to the skin, eyes, and immune system. Fortunately, a layer of ozone in the atmosphere absorbs most of the sun's damaging ultraviolet rays before they reach the Earth. Without this protective ozone layer, life on Earth would be impossible. However, scientists believe that chemicals released into the atmosphere by aerosol propellants, air-conditioning coolants, and various other sources are now destroying this protective ozone layer.

The energy of X rays is great enough to pass easily through many materials, including your skin. When an X ray picture of your body is taken, the bones absorb the rays but the soft tissues do not. The picture that results shows the bones as white areas and the soft tissues as black areas. Despite this medical usefulness, X rays are a potential health hazard. Exposure of body cells and tissues to large amounts of X rays over a lifetime can cause defects in cells.

The electromagnetic waves with the highest frequencies and shortest wavelengths are called gamma rays. Gamma rays have the highest frequency of the electromagnetic spectrum. Certain radioactive materials and nuclear reactions emit gamma rays. Gamma rays have tremendous penetrating ability; their energy is so great that they can penetrate up to 3 meters of concrete. Gamma rays have positive applications in medicine. A patient under observation can be injected with a fluid that emits gamma rays. A camera that detects gamma rays can then be moved around the patient to form an image of the inside of the body according to how the rays are given off. Concentrated gamma rays are destructive to human cells and can be used to kill cancerous cells. People who undergo gamma radiation therapy for cancer frequently suffer side effects, such as fatigue, nausea, and hair loss, from the therapy because healthy cells are also damaged.

Focusing Event: <Show the Physics for Fun: Light video on holograms and total internal reflection.> Ask the students to think of some applications of light and other electromagnetic waves. (AM and FM radio, television channels, radar, microwave, infrared heat lamps, UV sterilization, and X rays are a few examples.) <Have the students read the sections *The Electromagnetic Spectrum, Radio Waves, Infrared Radiation, Visible Radiation, Ultra Violet Radiation, and X rays and Gamma Rays* on pages 528 through 535 of their textbook.>

Instructional Procedures: <Play the video The Hole Story.> Discuss the following information taken from the video: formation of ozone, structure of chlorofluorocarbon, causes of ozone destruction, locations of ozone holes, effects of increased exposure to ultraviolet rays, and methods of preventing UV caused problems. <Hand out reinforcement and study guide worksheets on *Electromagnetic Radiation*.> The worksheets will be due at the beginning of class tomorrow.

Check for Understanding: I will check to make sure the students understand the topics we are discussing today. I will use examples that the students can easily relate to in order to reinforce the subject matter. During the videos, I will monitor the students to make sure they are cooperating by paying attention. Questions I may ask will be about the videos and about everyday applications of electromagnetic rays.

Guided Practice: The students will participate in a discussion about the applications of electromagnetic rays. By listening to their answers and discussion, I will be able to see if they understand the concept of the lesson. If the students are off track, I will help them understand with cues and questioning techniques.

Independent Practice: For homework the students are responsible for answering the questions on the worksheets *Electromagnetic Radiation Reinforcement* and *Electromagnetic Radiation Study Guide*.

Closure: Today, we learned about the applications of different parts of the electromagnetic spectrum. Can any one list the electromagnetic waves in the order of decreasing wavelength? (Radio, infrared, visible light, ultraviolet, X rays, and gamma rays.) What is an application of radio waves? (Microwave ovens, cellular telephones, and radio communications.) What is an application of infrared radiation? (Thermograms and heat lamps for food.) What is an application of visible radiation? (Decomposition of hydrogen peroxide and photosynthesis.) What is an example of ultraviolet radiation? (Vitamin D production and UV lamps to kill microorganisms.) What is an application of X ray radiation? (X ray photographs for detecting broken bones.) What is an application of gamma radiation? (Gamma radiation therapy to tree cancer.) What harmful radiation does the ozone layer protect us from? (Ultraviolet radiation.) How does the ozone layer function to protect us from the sun's harmful ultraviolet radiation? (The three oxygen atoms that combine to make each ozone molecule reside in the upper layer of the Earth's atmosphere. There they act as a natural filter blocking most of the sun's ultraviolet rays.) What has caused a reduction in the amount of ozone in the Earth's atmosphere? (Chemicals found in some spray-can propellants and refrigerants.)

Evaluation: The following factors will be considered to determine if the objective of this lesson plan was met: correctness of answers to the questions on the worksheets *Electromagnetic Radiation* Reinforcement and *Electromagnetic Radiation* Study Guide. The following rubric will be used to grade the assignment:

Task to be Completed	Number of Points Rewarded
<i>Electromagnetic Radiation</i> Reinforcement Worksheet	Each correct answer is worth 1 point for a total of 9 possible points in this section.
<i>Electromagnetic Radiation</i> Study Guide Worksheet	A correct answer is worth 1 point for a total of 15 possible points for this section.
Total number of points possible for this assignment	24

Grading Scale

A = 24-22 B = 21 C = 20-18 D = 17 F = 16 and below

Video Snapshots

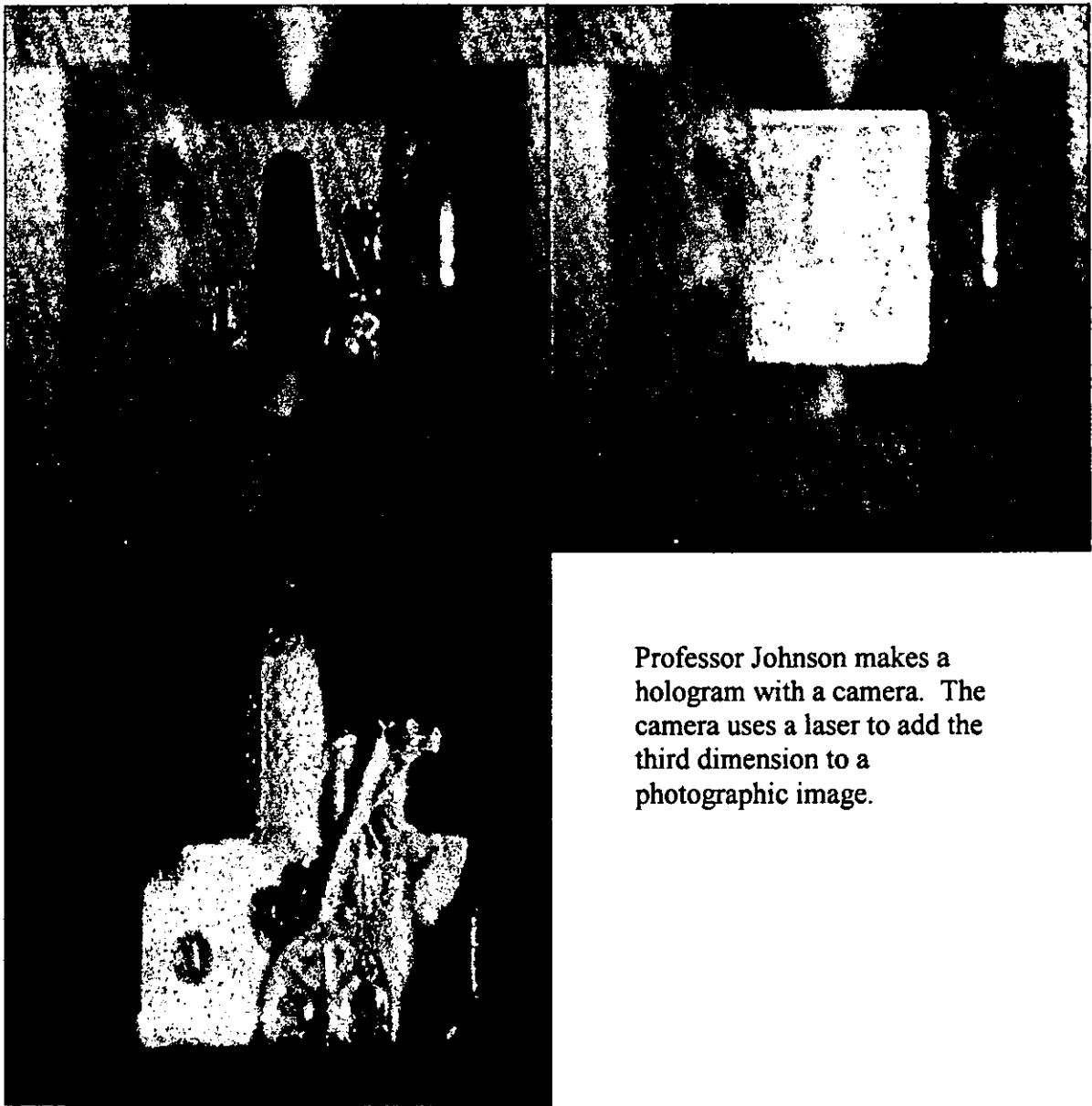
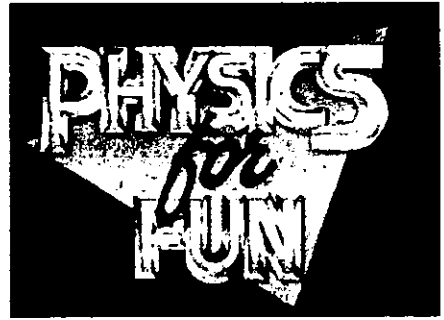

Professor Johnson makes a hologram with a camera. The camera uses a laser to add the third dimension to a photographic image.

REINFORCEMENT

• Electromagnetic Radiation

Use the diagram to answer questions 1-9.

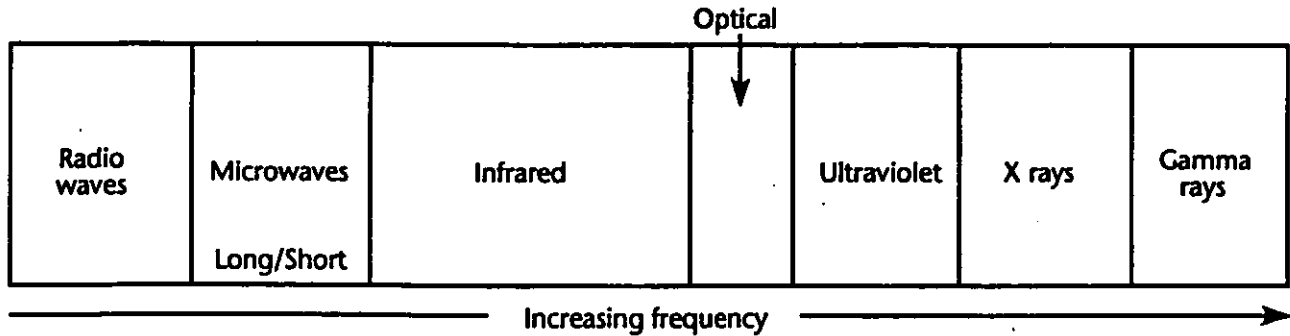

- _____ 1. The wavelength of an electromagnetic wave is _____.
 - a. directly proportional to its frequency
 - b. inversely proportional to its velocity
 - c. inversely proportional to its frequency
 - d. none of the above

- _____ 2. In a vacuum, all electromagnetic waves have _____.
 - a. the same frequency
 - b. the same velocity
 - c. the same wavelength
 - d. all of the above

- _____ 3. All electromagnetic radiation in the optical portion of the electromagnetic spectrum _____.
 - a. is visible
 - b. has the same wavelength
 - c. has the same frequency
 - d. all the above

- _____ 4. Compared to the photons of violet light, the photons of red light _____.
 - a. have more energy
 - b. have less energy
 - c. have equal energy
 - d. none of the above

- _____ 5. Compared to radio waves, microwaves have _____.
 - a. shorter wavelengths
 - b. photons with more energy
 - c. higher frequencies
 - d. all of the above

- _____ 6. Compared to gamma rays, X rays have _____.
 - a. longer wavelengths
 - b. higher frequencies
 - c. photons with more energy
 - d. all of the above

- _____ 7. We perceive infrared waves as _____.
 - a. coldness
 - b. light
 - c. warmth
 - d. none of the above

- _____ 8. Compared to gamma rays, radio waves have _____.
 - a. shorter wavelengths
 - b. higher frequencies
 - c. photons with less energy
 - d. none of the above

- _____ 9. All objects emit _____.
 - a. gamma rays
 - b. light
 - c. electromagnetic waves
 - d. none of the above

REINFORCEMENT

● Electromagnetic Radiation

Use the diagram to answer questions 1-9.

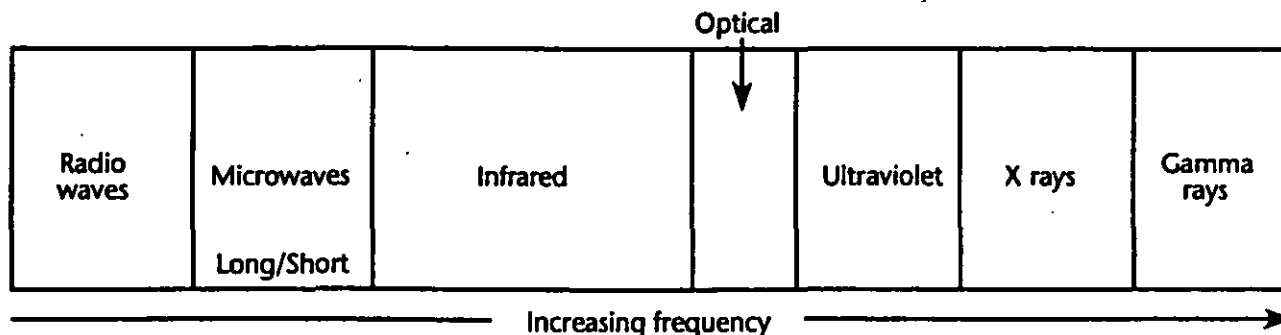

- C 1. The wavelength of an electromagnetic wave is _____.
- a. directly proportional to its frequency c. inversely proportional to its frequency
b. inversely proportional to its velocity d. none of the above
- B 2. In a vacuum, all electromagnetic waves have _____.
- a. the same frequency c. the same wavelength
b. the same velocity d. all of the above
- A 3. All electromagnetic radiation in the optical portion of the electromagnetic spectrum _____.
- a. is visible c. has the same frequency
b. has the same wavelength d. all the above
- B 4. Compared to the photons of violet light, the photons of red light _____.
- a. have more energy c. have equal energy
b. have less energy d. none of the above
- D 5. Compared to radio waves, microwaves have _____.
- a. shorter wavelengths c. higher frequencies
b. photons with more energy d. all of the above
- A 6. Compared to gamma rays, X rays have _____.
- a. longer wavelengths c. photons with more energy
b. higher frequencies d. all of the above
- C 7. We perceive infrared waves as _____.
- a. coldness c. warmth
b. light d. none of the above
- C 8. Compared to gamma rays, radio waves have _____.
- a. shorter wavelengths c. photons with less energy
b. higher frequencies d. none of the above
- C 9. All objects emit _____.
- a. gamma rays c. electromagnetic waves
b. light d. none of the above

How Bright is the Light?

Holly Rubach
Eighth Grade
Physical Science
03-07-00
10:25 a.m. – 11:10 a.m.

Materials: Macintosh or IBM-compatible computer, Serial Box Interface or ULI, Data Logger, Vernier Light Sensor, meter stick, lamp with 100-watt bulb, masking tape, shoebox

Estimated Time: 45 minutes

State Goals: As a result of this lesson, students will have a working knowledge of the processes, techniques, methods, equipment, and available technology of science.

Lesson Objective: To identify the relationship between light intensity and distance.

Introduction: You may have noticed that a light appears to be brighter when you are close to it and dimmer when you are farther away. We know that there is a definite relationship between the intensity of light (measured in Lux) and the distance to the light source. It has been proven that doubling the distance to the light source will cause the light intensity to be $1/4$ as great; in other words, light intensity and distance fit an inverse square relationship, $1/x^2$.

Focusing Event: <Show video clip from Physics for Fun: Light on the properties of light.> Ask the students to think about when they are approaching a street light and then, when they are standing underneath one. Does the light appear to be brighter when you are standing close to it? Can you read a note just as easily when you are distant from the light source as you can when you are directly underneath it? The intensity of a light source depends on the distance to the light source. As we approach a light source the light intensity becomes greater, but how much greater? Today we are going to use a light sensor to measure the intensity of a light source at various distances.

Instructional Procedures: <Hand out experiment sheets to the class.> Have all of the materials needed for each group at the center of each table. The students will work with the others at their table in groups of four. Read to the students the introduction and the procedures provided on the *How Bright is the Light?* experiment sheet. Have the students look at *Figure 1* to help with their set up. Because we will need to work in the dark during this activity, I will instruct students to be cautious as they are moving around. I will have to monitor their progress closely because they may get a little distracted working with the lights off. During the period the students will make observations and collect and record data.

Check for Understanding: I will check to make sure the set-ups are correct for each group. I will help make any corrections needed. I will monitor the students to make sure they are on task. Questions I may ask will be about the computer setup or what the students are observing during their experiment.

Guided Practice: The students will work on the section *Processing the Data* after all of the data has been collected. By looking at the answers I will be able to see if they understand the concept of the lab. If the students are off track, I will help them understand with cues and questioning techniques.

Independent Practice: For homework the students are responsible for hypothesizing on the subject of the extension question.

Closure: Today, we learned about the relationship between light intensity and distance. What happened when we moved the light sensor further away from the lamp? (The intensity of light decreased.) By about what fraction did the light intensity change from 10 cm to 20 cm? (One-fourth.) Was that change the same from 15 cm to 30 cm and from 20 cm to 40 cm? (Yes.) So what does that tell us about the relationship between the light intensity and the distance? (The light intensity and distance fit an inverse square relationship.) If you were to move the light sensor 4 times further away from the light, by what fraction would the light intensity change? (The light intensity would be 1/16 as great.) Does the value of your adjusted light intensity at 40 cm amount to 1/16 the value of your adjusted light intensity at 10 cm? (Yes.) Tonight for your homework you need to look at the extension question, and hypothesize about whether or not light from other sources will have the same or similar results.

Evaluation: The following factors will be considered to determine if the objective of this lesson plan was met: accuracy of data representation on the graph printout and accuracy of answers on the section *Processing the Data*. The following rubric will be used to grade the assignment:

Task to be Completed	Number of Points Rewarded
Question 1 <i>Processing the Data</i>	A data table that provides all of the expected values will earn a total of 6 points for this section.
Question 2 (Graph) <i>Processing the Data</i>	A graph that displays the appropriate results is worth 6 points for a total of 6 points for this section
Questions 3-6 <i>Processing the Data</i>	Each correct answer is worth 2 points for a total of 8 points in this section.
Total number of points possible for this assignment	20

Note: Partial credit may be given for all three of the sections graded.

Grading Scale

A = 20-19 B = 18 C = 17-16 D = 15-14 F = 13 and below

Video Snapshots

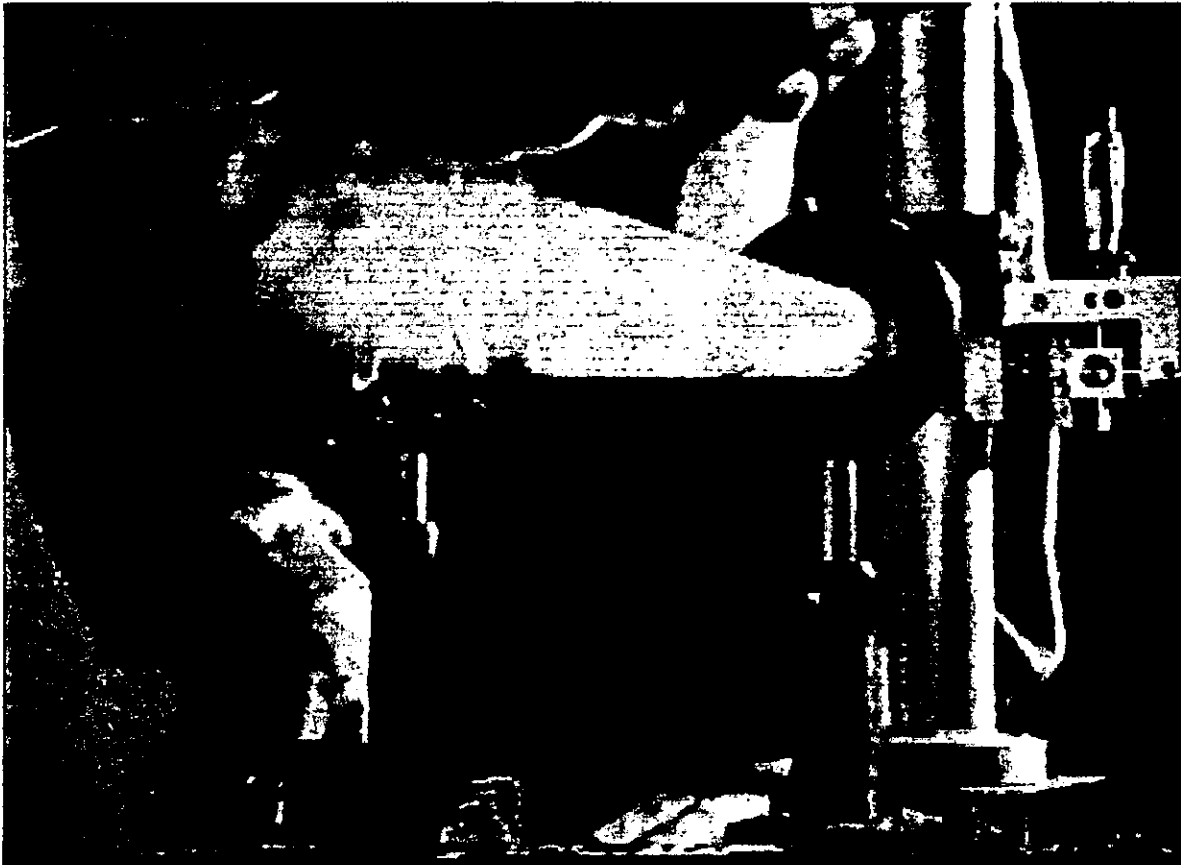
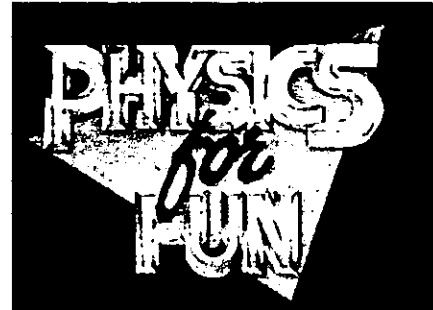

Professor Kristina Johnson and Larry Green use lasers to show that light travels in a straight line and can only be seen when it bounces off an object. Further demonstrations with lasers show that light is pure energy with no mass.

Video Snapshots

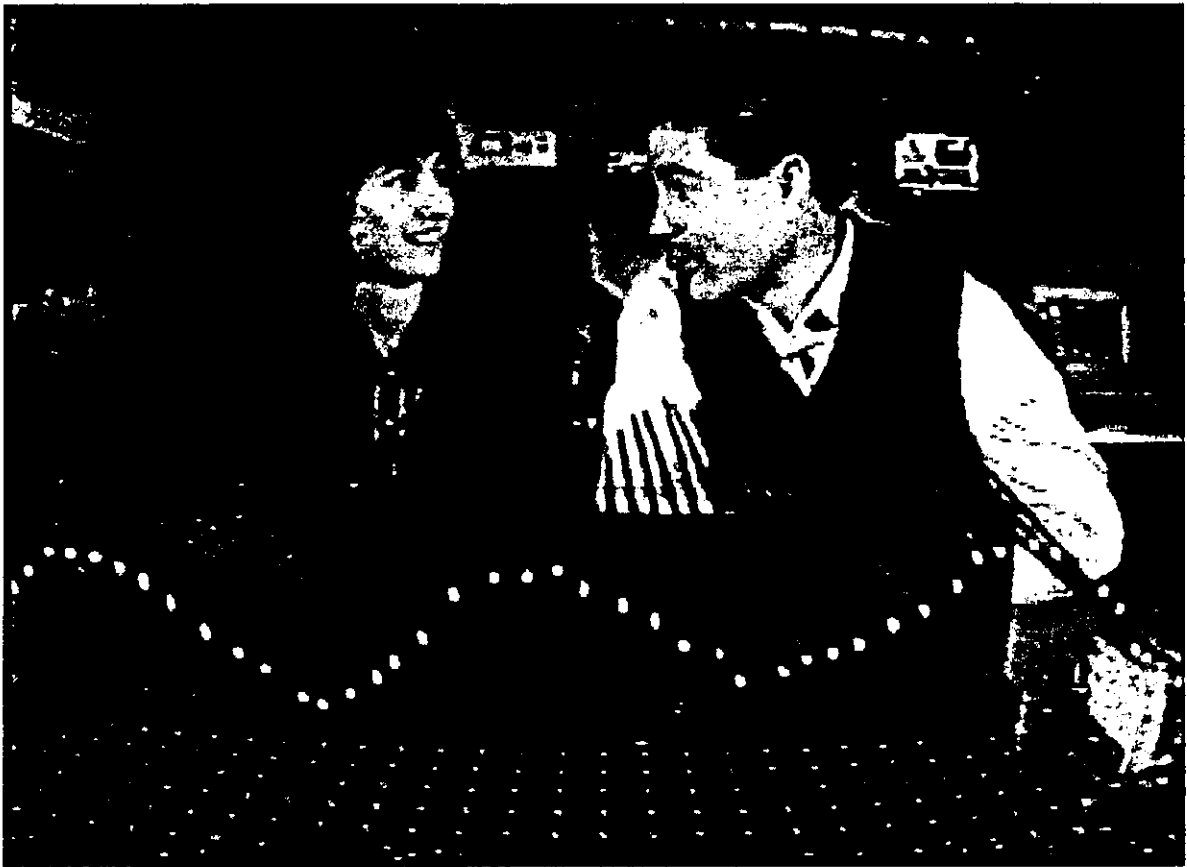
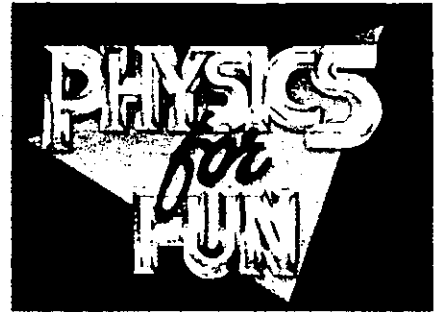

Light travels like a stadium wave. This movement is called a transverse wave. The waves move up and down, but the energy moves across.

How Bright is the Light?

You may have noticed that a light appears to be brighter when you are close to it, and dimmer when you are farther away. In this experiment, you will use a computer-interfaced light sensor to measure light intensity as you study the relationship between light intensity and distance.

OBJECTIVES

In this experiment, you will

- use a computer to measure light intensity
- graph and analyze data
- make conclusions about the relationship between light intensity and distance

MATERIALS

Macintosh or IBM-compatible computer
Serial Box Interface or ULI
Data Logger
Vernier Light Sensor

meter stick
lamp with 100-watt bulb
masking tape
shoe box

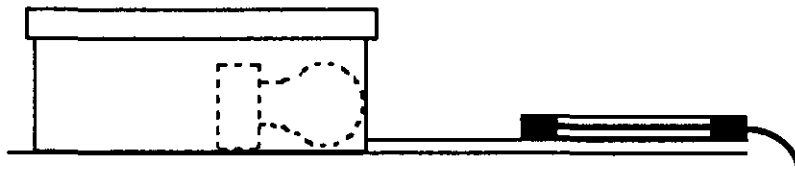

Figure 1

PROCEDURE

1. Set up the equipment.

- Tape a meter stick to your table top.
- Place a shoebox, with a small hole in the end, at the 0-cm mark of the meter stick as shown in Figure 1.
- Place a lamp into the shoebox. The bulb should be at the small hole.
- Tape the lamp in position to keep it from moving during the experiment. Cover the box with its lid.
- Place your light sensor on the meter stick and line up the box's small hole with the light sensor. Make sure the light sensor is set at the 0-600 Lux position.
- Darken the room. Do not turn on your light yet.

2. Prepare the computer for data collection by opening "EXP25.LXP" from the *Physical Science with Computers* experiment files of Data Logger. Open the calibration file "EXP25.CLB". The vertical axis will have illumination scaled from 0 to 500 Lux. The horizontal axis will have distance scaled from 0 to 50 cm.
3. Begin data collection.
 - Click on the Start button.
 - Position the end of the light sensor at the 10-cm line and turn on the light. When the reading has stabilized, click on the Keep button.
 - Enter "10" in the Distance edit box (for 10 cm).
 - Click on the OK button. The illumination value and the distance are now saved.
 - Move the light sensor to the 15-cm line. When the reading has stabilized, click on the Keep button. Enter "15" (for 15 cm), and then click on the OK button.
 - Repeat this procedure at 5-cm intervals through 40 cm.
4. Click on the Stop button to end data collection. Choose Data A Table from the Windows menu. Record the saved light intensity values in the first column of the data table below. Close the Data A Table window.
5. Turn the light off and repeat Steps 3 and 4 to get BACKGROUND LIGHT INTENSITY data. To accurately measure the intensity of light from sources other than the bulb at each interval, team members should again do the same tasks from the same positions.

DATA

Distance (cm)	Light Intensity (Lux)	Background Intensity (Lux)	Adjusted Intensity (Lux)
10	_____	_____	_____
15	_____	_____	_____
20	_____	_____	_____
25	_____	_____	_____
30	_____	_____	_____
35	_____	_____	_____
40	_____	_____	_____

PROCESSING THE DATA

1. Calculate the adjusted light intensity at each distance by subtracting the background intensity (Column 3) from the corresponding light intensity (Column 2). Record the results in Column 4 of the data table.
2. Graph your adjusted data. Plot the DISTANCE (in cm) on the horizontal axis and the ADJUSTED LIGHT INTENSITY (in Lux) on the vertical axis. Connect your points with a smooth curve. Describe your graph.

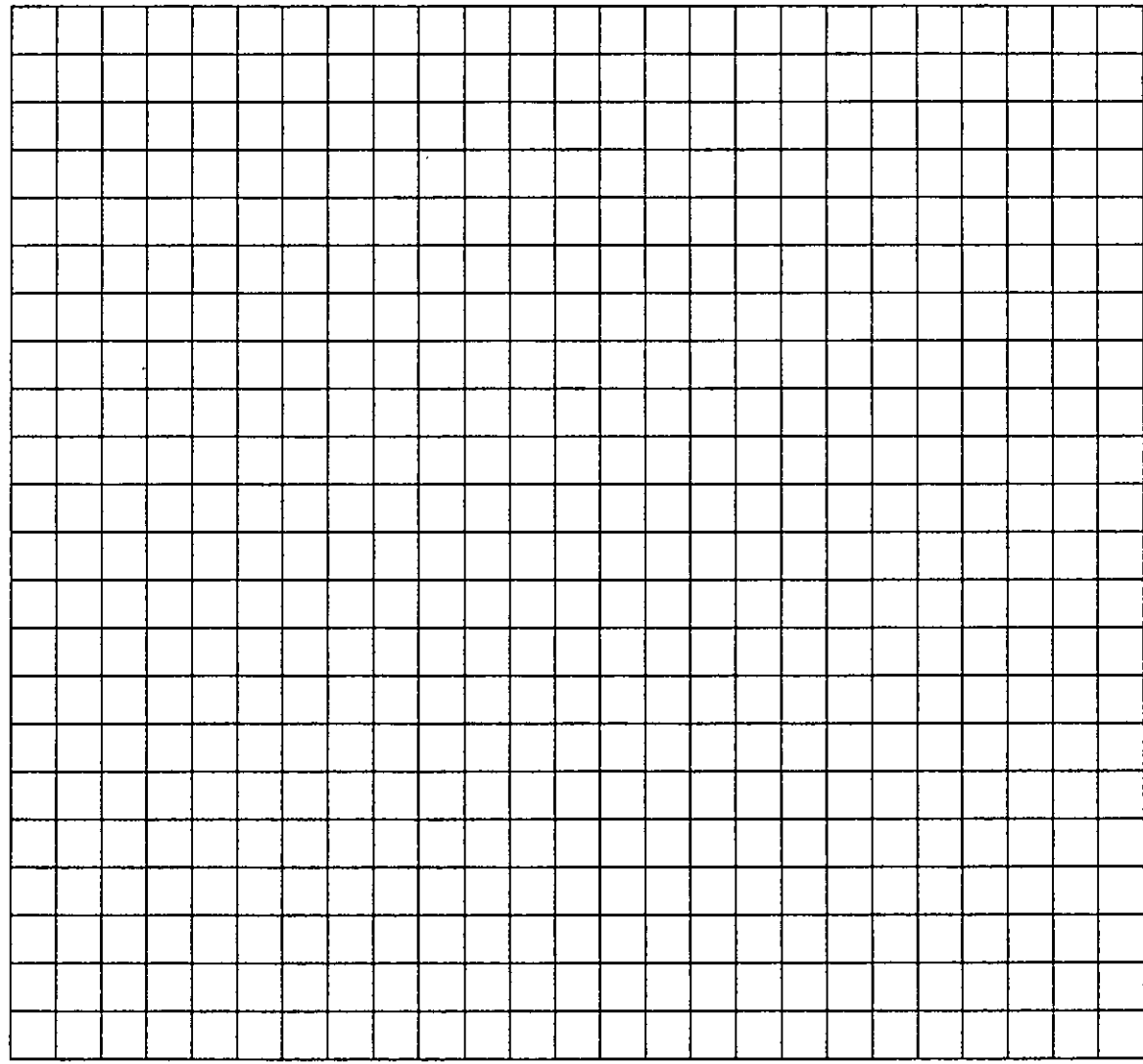

3. A light intensity curve showing an inverse square relationship looks like this:

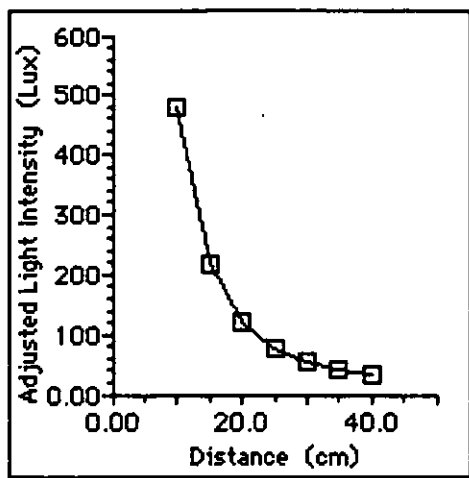

How well does your graph compare with this shape? Describe any differences.

4. If light intensity and distance fit an inverse square relationship, doubling the distance would cause light intensity to be $1/4$ as great. See how well your data agree by dividing the light intensity at 30 cm by the light intensity at 15 cm. Show your work below. How close is your value to 0.25 ($1/4$)? Does your data support an inverse square relationship for light intensity and distance?
5. If you would move the light sensor 5 times further away from the light, by what fraction would the light intensity change?
6. Summarize the results of this experiment.

EXTENSION

1. Test other light source types and compare the results.

Experiment
25

**TEACHER INFORMATION
AND ANSWER KEY**

How Bright is the Light?

1. The shoe box in the procedure is used to provide a small light source, approximating a point source. The inverse square law is only completely valid for point sources. Place a hole with a 0.5 cm diameter in the box end at a height of the light sensor when positioned on a meter stick as shown in Figure 1. Cut a small slot to accommodate the lamp cord at the top of the opposite end. Enclosing the bulb also reduces interference with concurrent student experiments.
2. The results shown on the following page were obtained using a 100-watt bulb. Good results can be obtained with 40-, 60-, and 75-watt bulbs.
3. Some teachers may want to do this experiment using very small, clear, DC lamps. The filaments of these lamps are small enough that they approximate a point light source. The need for the shoe box is eliminated.
4. Try to minimize variations in background light intensity, resulting from factors such as windows and room lights, during this experiment.
5. You can use Vernier Graphical Analysis to verify the inverse square relationship between light intensity and distance. Input the data, then create a modified column of data with the heading "Distance⁻²" to represent $1/d^2$. Graph Adjusted Intensity vs. Distance⁻². A straight line that passes through the origin verifies an inverse square relationship.

How Bright is the Light?

You may have noticed that a light appears to be brighter when you are close to it, and dimmer when you are farther away. In this experiment, you will use a computer-interfaced light sensor to measure light intensity as you study the relationship between light intensity and distance.

OBJECTIVES

In this experiment, you will

- use a computer to measure light intensity
- graph and analyze data
- make conclusions about the relationship between light intensity and distance

MATERIALS

Macintosh or IBM-compatible computer
Serial Box Interface or ULI
Data Logger
Vernier Light Sensor

meter stick
lamp with 100-watt bulb
masking tape
shoe box

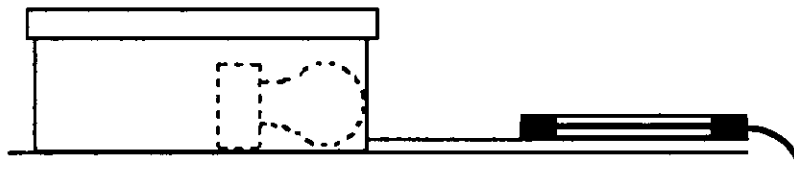

Figure 1

PROCEDURE

1. Set up the equipment.

- Tape a meter stick to your table top.
- Place a shoebox, with a small hole in the end, at the 0-cm mark of the meter stick as shown in Figure 1.
- Place a lamp into the shoebox. The bulb should be at the small hole.
- Tape the lamp in position to keep it from moving during the experiment. Cover the box with its lid.
- Place your light sensor on the meter stick and line up the box's small hole with the light sensor. Make sure the light sensor is set at the 0-600 Lux position.
- Darken the room. Do not turn on your light yet.

2. Prepare the computer for data collection by opening "EXP25.LXP" from the *Physical Science with Computers* experiment files of Data Logger. Open the calibration file "EXP25.CLB". The vertical axis will have illumination scaled from 0 to 500 Lux. The horizontal axis will have distance scaled from 0 to 50 cm.
3. Begin data collection.
 - Click on the Start button.
 - Position the end of the light sensor at the 10-cm line and turn on the light. When the reading has stabilized, click on the Keep button.
 - Enter "10" in the Distance edit box (for 10 cm).
 - Click on the OK button. The illumination value and the distance are now saved.
 - Move the light sensor to the 15-cm line. When the reading has stabilized, click on the Keep button. Enter "15" (for 15 cm), and then click on the OK button.
 - Repeat this procedure at 5-cm intervals through 40 cm.
4. Click on the Stop button to end data collection. Choose Data A Table from the Windows menu. Record the saved light intensity values in the first column of the data table below. Close the Data A Table window.
5. Turn the light off and repeat Steps 3 and 4 to get BACKGROUND LIGHT INTENSITY data. To accurately measure the intensity of light from sources other than the bulb at each interval, team members should again do the same tasks from the same positions.

DATA (Sample Results)

Distance (cm)	Light Intensity (Lux)	Background Intensity (Lux)	Adjusted Intensity (Lux)
10	<u>484</u>	<u>3.91</u>	<u>480</u>
15	<u>220</u>	<u>5.38</u>	<u>215</u>
20	<u>125</u>	<u>5.87</u>	<u>119</u>
25	<u>83.1</u>	<u>6.84</u>	<u>76.3</u>
30	<u>61.1</u>	<u>7.33</u>	<u>53.8</u>
35	<u>49.9</u>	<u>7.82</u>	<u>42.1</u>
40	<u>41.5</u>	<u>7.33</u>	<u>34.2</u>

PROCESSING THE DATA

1. Calculate the adjusted light intensity at each distance by subtracting the background intensity (Column 3) from the corresponding light intensity (Column 2). Record the results in Column 4 of the data table.

See sample results on Data Table.

2. Graph your adjusted data. Plot the DISTANCE (in cm) on the horizontal axis and the ADJUSTED LIGHT INTENSITY (in Lux) on the vertical axis. Connect your points with a smooth curve. Describe your graph.

Answers will vary.

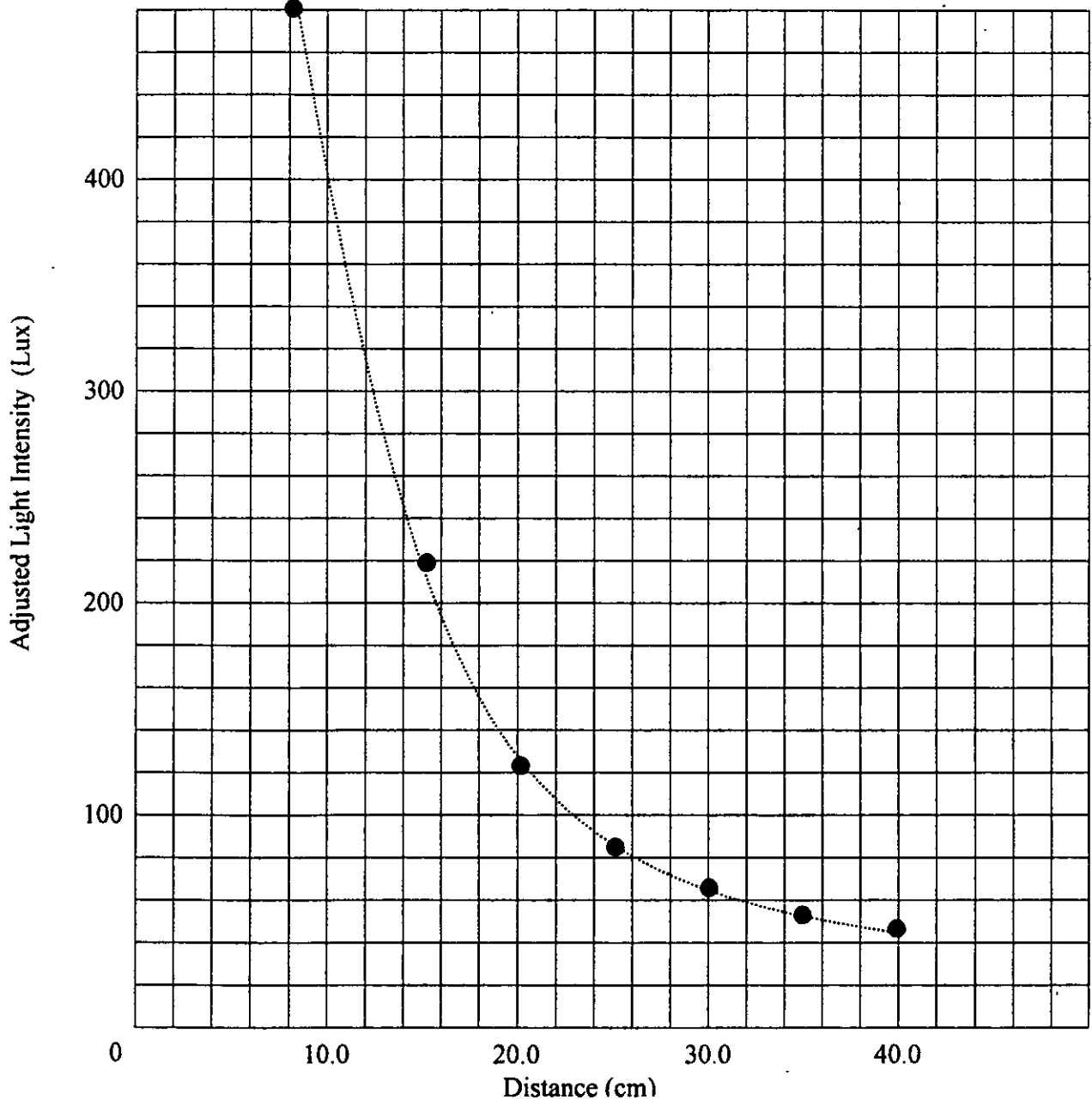

3. A light intensity curve showing an inverse square relationship looks like this:

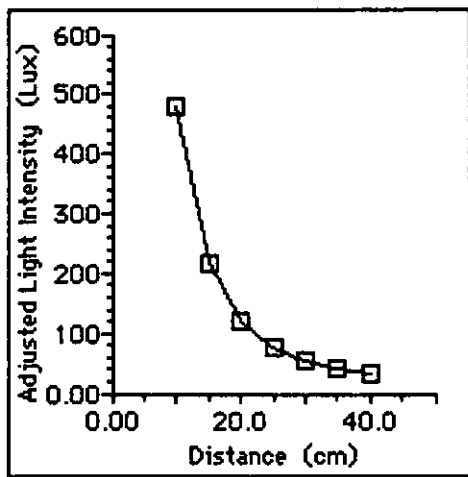

How well does your graph compare with this shape? Describe any differences.

Student graphs should have the same general shape as the graph shown.

4. If light intensity and distance fit an inverse square relationship, doubling the distance would cause light intensity to be $1/4$ as great. See how well your data agree by dividing the light intensity at 30 cm by the light intensity at 15 cm. Show your work below. How close is your value to 0.25 ($1/4$)? Does your data support an inverse square relationship for light intensity and distance?

Using adjusted data

for 20 cm and 10 cm, $119/480 = 0.248$

for 30 cm and 15 cm, $53.8/215 = 0.250$

for 40 cm and 20 cm, $34.2/119 = 0.287$

$(0.248 + 0.250 + 0.287)/3 = 0.262$ These values are close to the expected 0.25 value and support an inverse square relationship for light intensity and distance.

5. If you would move the light sensor 5 times further away from the light, by what fraction would the light intensity change?

If the light sensor would be moved five times further away from the light source, the intensity would become $1/25$ as great.

6. Summarize the results of this experiment.

Light intensity varies inversely with the square of distance. (Students answers will vary.)

EXTENSION

1. Test other light source types and compare the results.

Light and Color

Holly Rubach
Eighth Grade
Physical Science
03-08-00
10:25 a.m. – 11:10 a.m.

Materials: colored paper, colored cellophane, slides of primary colors of light, large square of tin foil, large square of wax paper, large square of saran wrap, large square of wax paper, primary pigment paints, mixing tray for paints

Estimated Time: 45 minutes

State Goals: As a result of this lesson, students will have a working knowledge of the processes, techniques, methods, equipment, and available technology of science.

Lesson Objective: To describe the differences among opaque, transparent, and translucent; to explain how you see color; to describe the difference between light color and pigment color.

Introduction: Opaque materials absorb or reflect light, and you cannot see objects through them. Transparent materials allow light to pass through and you can clearly see objects through them. Translucent materials allow some light through, but you cannot see objects clearly through them. A white opaque material appears white because it reflects all of the colors of the spectrum – red, orange, yellow, green, blue, indigo, and violet. Grass appears green because it reflects green light and absorbs the rest of the colors in the visible spectrum. The primary colors of light are red, blue, and green. Mixing red and blue light gives rise to magenta, blue and green light gives rise to cyan, and green and red light gives rise to yellow. The eye uses special photoreceptor cells called cone cells to allow you to distinguish between colors. About eight percent of men and one-half percent of women have a problem with their sets of color receptors; this condition is sometimes called color blindness because it results in an inability to distinguish between certain colors. The three primary pigment colors are cyan, magenta, and yellow. When all three are mixed the result is the color black. Mixing the pigments cyan and magenta produces the color blue, mixing the pigments yellow and cyan produces the color green, and mixing the pigments yellow and magenta produces the color red.

Focusing Event: <Show the video clip from Physics for Fun: Light that demonstrates the speed of light.> Ask the students to explain how they can form a new color from pre-existing colors. Ask them if they know the difference between pigment color and light color. <Have the students read the section *Light and Color* on pages 536 through 541 of their textbook.>

Instructional Procedures: <Hand out experiment sheets to the class.> Hold up aluminum foil, wax paper, and saran wrap. Ask students to make observations about how well each

absorbs, reflects, or transmits light. Explain that the aluminum foil is opaque, the wax paper is translucent, and the saran wrap is transparent. Ask them to give additional examples of each. Ask them to explain why we see objects in different colors. Explain that we see an object a certain color because that object reflects that specific color. Use the colored cellophane sheets to cover various sheets of colored paper and ask the students to guess what color the paper is. Explain that the plastic sheet is a filter that transmits one or more colors of light but absorbs all others. The color of a filter is the same as the color of light it transmits. Ask the students if they can name the three primary light colors. They may name the primary pigment colors instead. Children learn red, yellow, and blue from their art education. Emphasize that the primary pigment colors are different from the primary light colors. Explain that red, green, and blue are the primary colors of light. By placing red, blue, and green transparency film on an overhead projector demonstrate how red and green overlap to make yellow, red and blue make magenta, and green and blue make cyan. Discuss how the eye perceives different colors, and discuss color blindness. Ask the students to name the three primary pigment colors. Demonstrate how you can make any pigment color by mixing different amounts of the three primary pigments – magenta, cyan, and yellow; use paints and a mixing tray. <Hand out reinforcement and study guide worksheets on *Light and Color*.> The worksheets will be due at the beginning of class tomorrow.

Check for Understanding: I will check to make sure the students understand the topics we are discussing today. I will use examples that the students can easily relate to in order to reinforce the subject matter. During the video, I will monitor the students to make sure they are cooperating by paying attention. Questions I may ask will be about the video, the differences between opaque, translucent, and transparent materials, and the differences between primary pigment colors and primary light colors.

Guided Practice: The students will participate in the discussion about light and color. By listening to their answers and discussion, I will be able to see if they understand the concept of the lesson. If the students are off track, I will help them understand with cues and questioning techniques.

Independent Practice: For homework the students are responsible for answering the questions on the worksheets *Light and Color Reinforcement* and *Light and Color Study Guide*.

Closure: Today, we learned about light and color. First, we discussed light in regards to matter. What is a material that absorbs or reflects all light called? (Opaque.) What is an example of an opaque object? (A textbook.) What do you call a material that allows light to pass through and you can clearly see objects through? (Transparent.) What is an example of a transparent object? (A windowpane.) What do you call a material that allows some light to pass through, but you cannot clearly see objects through them? (Translucent.) What is an example of a translucent object? (Sheer shower curtains.) What are the three primary light colors? (Red, blue, and green.) What are the three primary pigment colors? (Yellow, magenta, and cyan.) A mixture of all three of the primary light colors creates what? (White light.) A mixture of the primary pigment colors produces what color? (Black.) If white light shines on a red shirt, what colors are reflected and what colors are absorbed? (Red is

reflected; all others are absorbed.) Remember to bring your two homework worksheets to class tomorrow completed.

Evaluation: The following factors will be considered to determine if the objective of this lesson plan was met: correctness of answers to the questions on the worksheets *Light and Color Reinforcement* and *Light and Color Study Guide*. The following rubric will be used to grade the assignment:

Task to be Completed	Number of Points Rewarded
<i>Light and Color Reinforcement Worksheet</i>	Each correct answer is worth 1 point for a total of 18 possible points in this section.
<i>Light and Color Study Guide Worksheet</i>	A correct answer is worth 1 point for a total of 19 possible points for this section.
Total number of points possible for this assignment	37

Grading Scale

A = 37-34 B = 33-32 C = 31-28 D = 27-26 F = 25 and below

Grading Scale

A = 20-19 B = 18 C = 17-16 D = 15-14 F = 13 and below

Chapter 19

Use with Text Pages 536-543

REINFORCEMENT

● Light and Color

Solve the following crossword puzzle by using the clues provided.

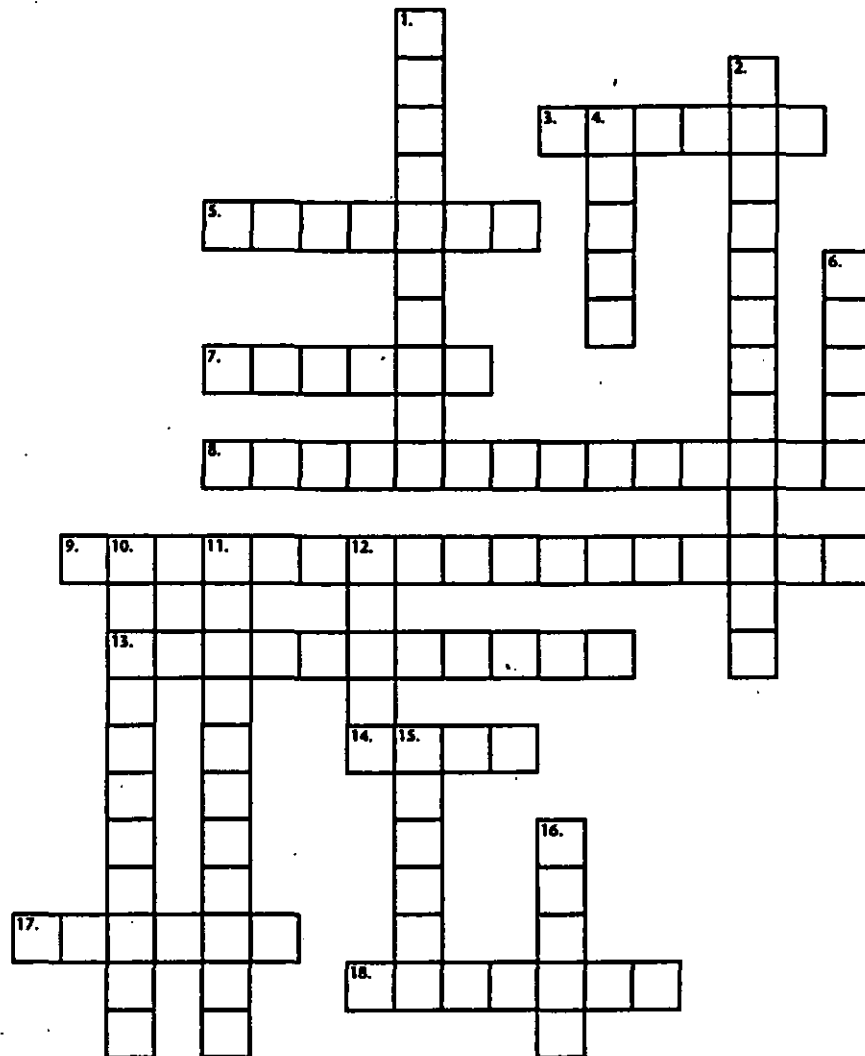

Across

3. Soak up, for example, light rays
5. Colored material that absorbs some colors but reflects others
7. Color that results from mixing red and yellow pigments
8. Primary light colors are this type.
9. Primary pigments are this type.
13. Allows some light to pass without your being able to see through clearly
14. Type of nerve cells on retina that allow you to see dim light
17. Transparent object that allows one or more colors through but absorbs others
18. What an object does to light so we see it

Down

1. Light produced by mixing all colors of the visible spectrum
2. Colors that can be mixed to produce any other colors
4. Color of an object that absorbs all light
6. Nerve cells you use to distinguish colors
10. This type of radiation lies just outside the high-frequency end of the visible spectrum.
11. Allowing nearly all light to pass through
12. What you see when reflected wavelengths of light reach your eyes
15. Material you cannot see through
16. The color you see if you are looking at light that has no red or blue

Chapter 19

Use with Text Pages 536-543

REINFORCEMENT

● Light and Color

Solve the following crossword puzzle by using the clues provided.

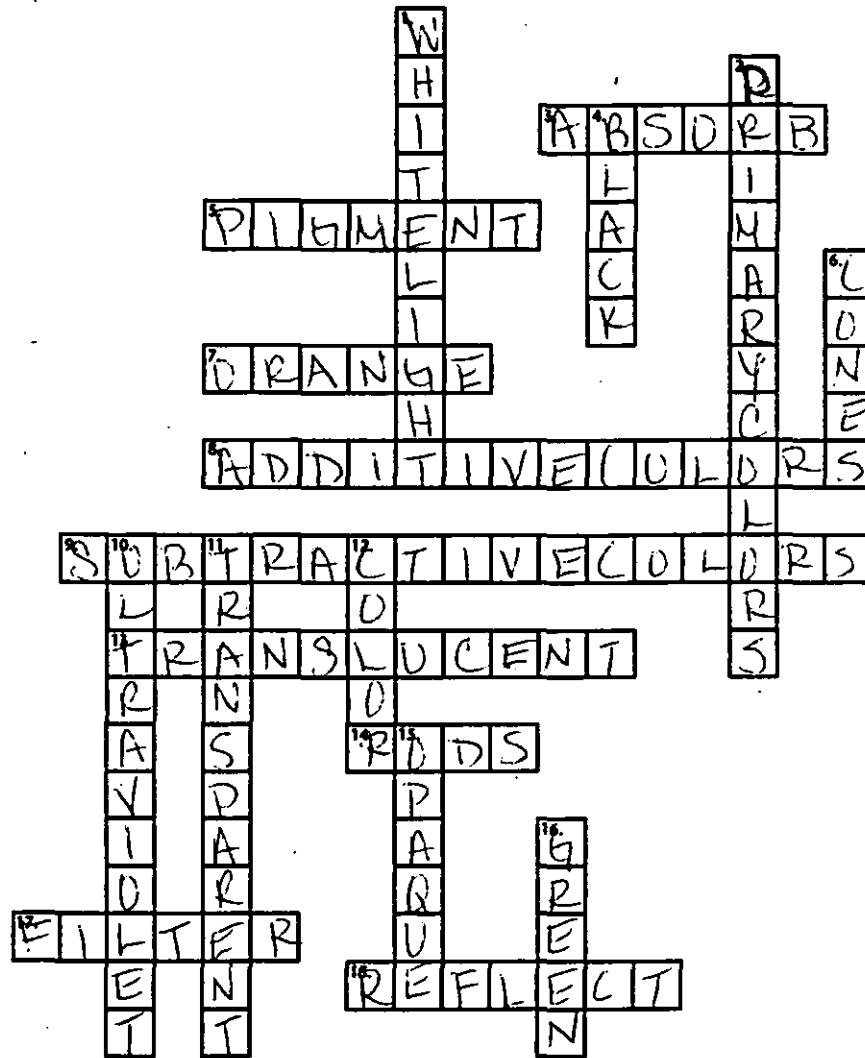

Across

3. Soak up, for example, light rays
5. Colored material that absorbs some colors but reflects others
7. Color that results from mixing red and yellow pigments
8. Primary light colors are this type.
9. Primary pigments are this type.
13. Allows some light to pass without your being able to see through clearly
14. Type of nerve cells on retina that allow you to see dim light
17. Transparent object that allows one or more colors through but absorbs others
18. What an object does to light so we see it

Down

1. Light produced by mixing all colors of the visible spectrum
2. Colors that can be mixed to produce any other colors
4. Color of an object that absorbs all light
6. Nerve cells you use to distinguish colors
10. This type of radiation lies just outside the high-frequency end of the visible spectrum.
11. Allowing nearly all light to pass through
12. What you see when reflected wavelengths of light reach your eyes
15. Material you cannot see through
16. The color you see if you are looking at light that has no red or blue

Chapter 19

Use with Text Pages 536-543

STUDY GUIDE**● Light and Color***Use the words in the box to fill in the blanks.*

translucent	primary	opaque	black	transmits	colors
white	cone	absorbs	transparent	reflect	filter

For you to see an object, it must _____ light. A material through which nearly all light passes is _____. A material that you cannot see through clearly is _____. _____ objects cannot be seen through. _____ light is a mixture of all visible wavelengths of the spectrum. _____ objects absorb all colors and reflect little light. Red, blue, and green are the three _____ colors of light. They can be mixed to produce any color.

The retina contains _____ cells that detect certain wavelengths of light. When the brain responds to these signals, we see _____.

One way of producing color is by the use of a _____, a transparent object that _____ some colors and allows others to pass through. The color of the filter is the same as the color of light it _____.

Use the words in the box to fill in the blanks.

cyan	filter	pigment	additive
subtractive	black	reflected	

A colored material that absorbs certain colors and reflects others is a _____. To mix and make any color, it is necessary to have only three primary pigment colors—magenta, yellow, and _____. Light color is determined by the wavelength of light transmitted through a _____. Pigment color is determined by the wavelength of light _____ from pigment particles.

Because primary light colors combine to produce white light, they are called _____ colors. If all primary pigments are added equally, the result will be _____. Because black results from the absence of reflected light, the primary pigment colors are called _____ colors.

Chapter 19

Use with Text Pages 536-543

STUDY GUIDE

● Light and Color

Use the words in the box to fill in the blanks.

translucent white	primary cone	opaque absorbs	black transparent	transmits reflect	colors filter
----------------------	-----------------	-------------------	----------------------	----------------------	------------------

For you to see an object, it must reflect light. A material through which nearly all light passes is transparent. A material that you cannot see through clearly is translucent. Opaque objects cannot be seen through. White light is a mixture of all visible wavelengths of the spectrum. Black objects absorb all colors and reflect little light. Red, blue, and green are the three primary colors of light. They can be mixed to produce any color.

The retina contains cone cells that detect certain wavelengths of light. When the brain responds to these signals, we see colors.

One way of producing color is by the use of a filter, a transparent object that absorbs some colors and allows others to pass through. The color of the filter is the same as the color of light it transmits.

Use the words in the box to fill in the blanks.

cyan subtractive	filter black	pigment reflected	additive
---------------------	-----------------	----------------------	----------

A colored material that absorbs certain colors and reflects others is a pigment. To mix and make any color, it is necessary to have only three primary pigment colors—magenta, yellow, and cyan. Light color is determined by the wavelength of light transmitted through a filter. Pigment color is determined by the wavelength of light reflected from pigment particles.

Because primary light colors combine to produce white light, they are called additive colors. If all primary pigments are added equally, the result will be black. Because black results from the absence of reflected light, the primary pigment colors are called subtractive colors.

Reflection

Holly Rubach
Eighth Grade
Physical Science
03-09-00
10:25 a.m. – 11:10 a.m.

Materials: each group should be provided with the following supplies: a copy of the lab *Mirrors and Rays of Light*, thick chalkboard (1 sheet), unlined paper (1 sheet), mirror support, straight pins (2), plane mirror, cellophane tape, meter stick, protractor, a copy of the reinforcement worksheet *Wave Properties of Light*, and a copy of the study guide worksheet *Wave Properties of Light*

Estimated Time: 45 minutes

State Goals: As a result of this lesson, students will have a working knowledge of the processes, techniques, methods, equipment, and available technology of science. The processes utilized include the following: observing, comparing, recording, measuring, using space-time relationships, and inferring.

Lesson Objective: To correctly measure the angle of incidence and the angle of reflection and to discover the relationship between these angles.

Introduction: Rough, light-colored surfaces such as sand and paper reflect much light. Smooth, shiny surfaces also reflect much light but in a different way. When you look at a shiny surface, you can see a likeness, or image, of objects facing the surface. Silver, aluminum, and other metals have smooth, shiny surfaces. Mirrors are made by coating a piece of glass with silver or aluminum. Light that strikes the glass is transmitted through the glass but is reflected by the metal coating. When an object is placed in front of a mirror, the reflected image is very much like the object in front of it. Reflection occurs with all types of waves: electromagnetic waves, sound waves, and water waves. A light beam that strikes a mirror is referred to as the incident beam; the beam that bounces off the mirror is the reflected beam. A line can be drawn perpendicular to the mirror where the incident beam strikes the mirror and is reflected; this line is known as the normal. The angle formed by the incident beam and the normal is the angle of incidence; the angle formed by the reflected beam and the normal is the angle of reflection. The law of reflection states that the angle of incidence is equal to the angle of reflection. Any reflected light will always follow the law of reflection.

Focusing Event: <Show the video clip from Physics for Fun: Light video that demonstrates the angle of reflection as it relates to mirrors.> Ask the students to think about looking in a mirror, and then, have them describe how they think it reflects light. How far away does the person they see in the mirror appear to be? Are light waves the only kind of waves that can be reflected? <Have the students read the section *Reflection* on page 546 of their textbook.>

Instructional Procedures: <Hand out experiment sheets to the class.> Have all of the materials needed for each group at the center of each table. The students will work with the others at their table in groups of two. Read to the students the sections *Find Out*, *Background*, and *Expected Outcome* on the activity sheet. Then, ask the students to write a hypothesis regarding the relationship of the angle of incidence to the angle of reflection. Read the procedures to the students, and have them look at figure to help with their set up. During the period the students will follow the directions as outlined in the lab, they will make observations and will collect and record data. When all of the data has been collect, they will answer the activity review questions.

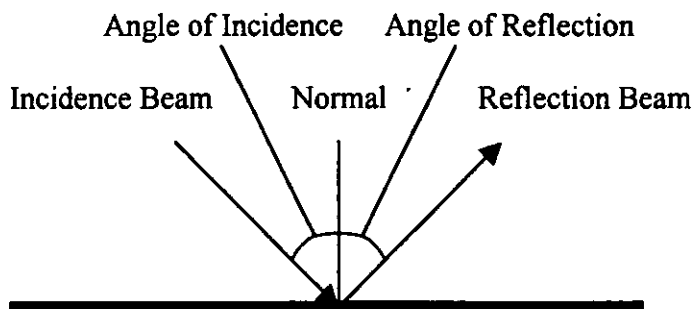

Angle of Incidence = Angle of Reflection

Check for Understanding: I will check to make sure the set-ups are correct for each group. I will help make any corrections needed. I will monitor the students to make sure they are on task. Questions I may ask will be about the setup of the mirror, pin, and marks *A*, *B*, *C*, and *D*, or I may ask the students to explain what they are observing during their experiment.

Guided Practice: The students will work on the section *Activity Review* after all of the data has been collected. By looking at the answers I will be able to see if they understand the concept of the lab. If the students are off track, I will help them understand with cues and questioning techniques.

Independent Practice: For homework the students are responsible for completing the *Wave Properties of Light* reinforcement and study guide worksheets.

Closure: Today, we discovered how light is reflected off of a mirror. What did we call the ray of light that travels toward a mirror? (The incidence beam.) What is the ray of light that bounces off the mirror called? (The reflected beam.) What are the angles of incidence and reflection? (The angle formed by the incident beam and the normal is the angle of incidence; the angle formed by the reflected beam and the normal is the angle of reflection.) What is the normal? (A line drawn perpendicular to the mirror where the incidence beam meets the reflected beam.) What is the relationship between the angle of incidence and the angle of reflection? (The law of reflection states that the angle of incidence is equal to the angle of reflection.) Tonight you are going to have two worksheets to complete for homework. They will be collected at the beginning of class tomorrow. Use your textbook as a reference if you have any questions when completing the assignment.

Evaluation: The following factors will be considered to determine if the objective of this lesson plan was met: accuracy of the measurements recorded in the data table, correctness of answers to questions one through seven on the lab handout, and correctness of answers to questions on the *Wave Properties of Light* reinforcement and study guide worksheets. Partial credit may be given for some of the questions. The following rubric will be used to grade the assignments:

Task to be Completed	Number of Points Rewarded
Data Table on the activity <i>Mirrors and Rays of Light</i>	A data table with reasonable answers will earn the student 6 points.
Questions 1-6 on the activity <i>Mirrors and Rays of Light</i>	A correct answer is worth 2 points for a total of 14 possible points in this section.
<i>Wave Properties of Light</i> Reinforcement	The blanks in <i>figure 1</i> and the three multiple choice questions are each worth 1 point, and the answer to <i>figure 2</i> is worth 2 points for a total of 10 possible points.
<i>Wave Properties of Light</i> Study Guide	Each blank is worth 1 point for a total of 19 possible points.
Total number of points possible for this assignment	49

Grading Scale

A = 49-46 B = 45-42 C = 41-37 D = 36-34 F = 33 and below

*** Note: Before beginning this activity, you may wish to instruct your students on how to use the protractor. They may not remember exactly where to set the protractor in order to measure an angle. In addition, you may wish to cut apart some cardboard boxes to obtain the thick cardboard the students will need for this activity. The cardboard can be cut easily if you have a cutting tool, such as a linoleum knife, that has a handle and a sharp cutting edge.

Video Snapshots

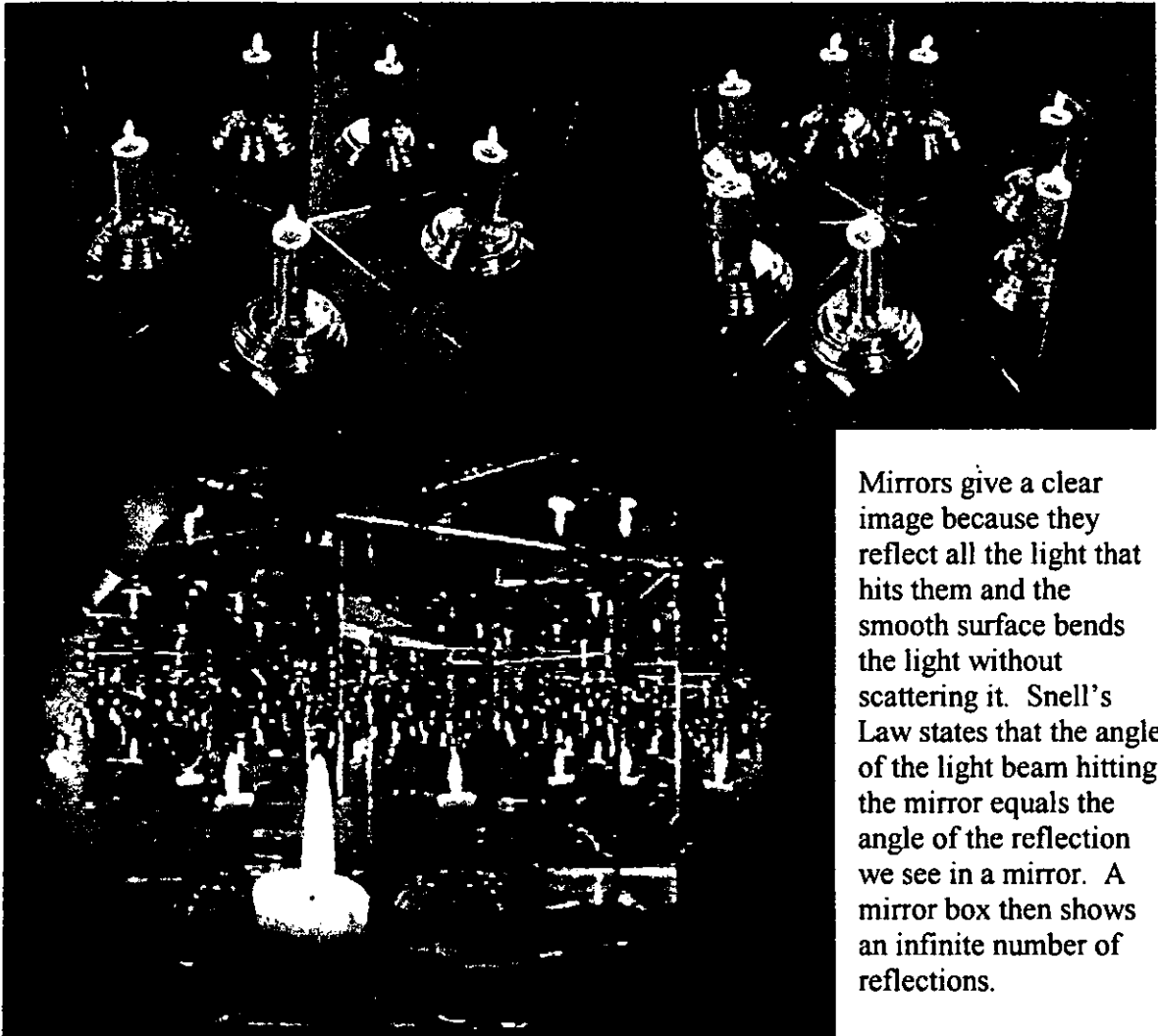
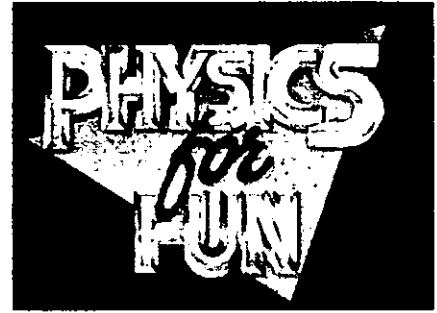

Mirrors give a clear image because they reflect all the light that hits them and the smooth surface bends the light without scattering it. Snell's Law states that the angle of the light beam hitting the mirror equals the angle of the reflection we see in a mirror. A mirror box then shows an infinite number of reflections.

ACTIVITY 42 Mirrors and Rays of Light

FIND OUT

How is the size of the angle at which a ray of light hits a plane mirror related to the size of the angle at which the same ray of light is reflected by the mirror?

YOU WILL NEED

thick cardboard (1 sheet)
unlined paper (1 sheet)
mirror support

straight pins (2)
plane mirror
cellophane tape

meter stick
protractor

BACKGROUND

A mirror is any smooth or highly polished surface which can be used to reflect rays of light in a regular way. Flat mirrors, such as those on the doors of medicine cabinets, are plane mirrors. Such mirrors always reflect rays of light in a regular way. For example, when you see an image of an object in a plane mirror, the image is very much like the object. That is, the image is clear, not upside down, and not changed in size.

EXPECTED OUTCOME

I think that the angle at which a ray of light hits a plane mirror (angle of incidence) is related to the size of the angle at which the same ray of light is reflected (angle of reflection) in the following way.

.....
.....
.....
.....
.....
.....

WHAT TO DO

You may work with other students in doing this activity. However, each person should record the data.

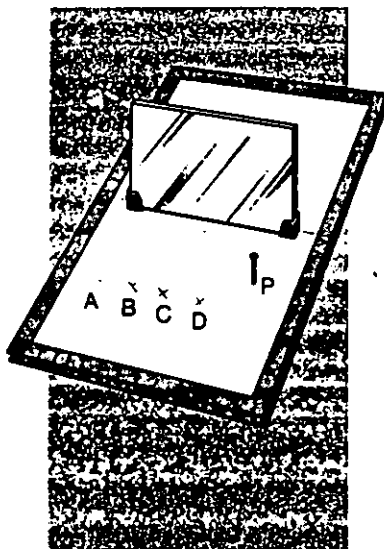

1. Tape a large sheet of paper to a large, flat piece of cardboard. Draw a line across the width of the paper. This line marks the position of the mirror and will be called the mirror line. Then attach the mirror support to the plane mirror and set the mirror on the mirror line. The reflecting surface of the mirror (the back side of a glass mirror) should be on the line. Mark the position of the mirror on the mirror line so that you can remove the mirror and put it back in exactly the same position.

2. Push a straight pin into the paper in front of the mirror. The pin should be stuck into the paper at a position (P) about ten centimeters from the mirror and toward the right-hand side of the paper. See the diagram.

3. Now make four pencil marks on the paper in front of the mirror and to the left of P. Label the marks A, B, C, and D (from left to right).

NAME _____

(Turn the page) 115

4. Stick a second pin into the paper at *A*. With one eye closed and with your head near the level of the top of the pin, look into the mirror and observe the image of the pin at *P*. Move your head so that the pin at *A* is in line with the image of the pin at *P* in the mirror. Keep the image in line with the pin at *A* and make a pencil mark on the paper directly in front of the mirror at the place where the image of the pin at *P* appears to be on the mirror.

5. Remove the pin at *A* and remove the mirror. Use the meter stick to draw a straight line starting from *A*, passing it through the mark you made in front of the mirror and extending it to the mirror line. Label the point on the mirror line *A'*. Now use the meter stick to draw a line from *P* to *A'*. The line from *P* to *A'* represents the path of a ray of light traveling from *P* to the mirror. The line from *A'* to *A* represents the path of the ray of light after it is reflected from *A'* to *A*.

6. Set the mirror on the mirror line again and repeat steps 4 and 5, using a pin stuck into the paper at *B*, at *C*, and then at *D*.

7. After drawing all the lines, use a protractor to measure the sizes of the angles made between each line you drew and the mirror line. Record these angles in the table below.

Angle	Measurement
Angle Between Line <i>PA'</i> and the Mirror Line	
Angle Between Line <i>AA'</i> and the Mirror Line	
Angle Between Line <i>PB'</i> and the Mirror Line	
Angle Between Line <i>BB'</i> and the Mirror Line	
Angle Between Line <i>PC'</i> and the Mirror Line	
Angle Between Line <i>CC'</i> and the Mirror Line	
Angle Between Line <i>PD'</i> and the Mirror Line	
Angle Between Line <i>DD'</i> and the Mirror Line	

ACTIVITY REVIEW Use the results you obtained to answer the following questions.

1. What do each of the points on the mirror line represent?

.....

.....

.....

.....

.....

2. How does the angle formed by line PA' and the mirror line compare with the angle formed by line AA' and the mirror line?

.....

.....

.....

3. How does the angle formed by line PB' and the mirror line compare with the angle formed by line BB' and the mirror line?

.....

.....

.....

4. How does the angle formed by line PC' and the mirror line compare with the angle formed by line CC' and the mirror line?

.....

.....

.....

5. How does the angle formed by line PD' and the mirror line compare with the angle formed by line DD' and the mirror line?

.....

.....

.....

6. Based on your results, how is the angle at which a ray of light hits a mirror related to the angle at which the ray of light is reflected?

.....

.....

.....

NAME _____

7. How do the results of this activity compare with your expected outcome?

.....

.....

.....

.....

.....

OPTIONAL The following activities are related to the activity you have just completed.

1. Obtain a convex mirror or a concave mirror. Support the mirror upright in some way. Try to measure the angles of incidence and reflection as you did for the plane mirror. What is the difficulty in measuring the angles?
2. Place a plane mirror at the bottom of an aquarium tank filled with water. Put a small amount of food coloring in the tank. Hold a flashlight above the tank at an angle so that the light reflects off the mirror and back up again. If you hold a protractor at the side of the tank, you should be able to measure the angles of incidence and reflection. Are the angles equal? Explain.
3. If possible, obtain some one-way glass. Try to find out how much light may be reflected with such glass. What happens to the light which is not reflected?
4. Obtain five plane mirrors and arrange them in a curve as shown on page 447 of your book. Using five flashlights, direct a beam of light at each of the mirrors. The beams should be parallel. What happens to the reflected light? Change the curvature of the five mirrors and direct the beams of light as before. What happens to the reflected light? In general, how do the angles of reflection for the first arrangement of mirrors compare to the angles of reflection for the second arrangement of mirrors? Explain.

ACTIVITY 42 Mirrors and Rays of Light

FIND OUT

How is the size of the angle at which a ray of light hits a plane mirror related to the size of the angle at which the same ray of light is reflected by the mirror?

YOU WILL NEED

thick cardboard (1 sheet)
unlined paper (1 sheet)
mirror support

straight pins (2)
plane mirror
cellophane tape

meter stick
protractor

BACKGROUND

A mirror is any smooth or highly polished surface which can be used to reflect rays of light in a regular way. Flat mirrors, such as those on the doors of medicine cabinets, are plane mirrors. Such mirrors always reflect rays of light in a regular way. For example, when you see an image of an object in a plane mirror, the image is very much like the object. That is, the image is clear, not upside down, and not changed in size.

EXPECTED OUTCOME

I think that the angle at which a ray of light hits a plane mirror (angle of incidence) is related to the size of the angle at which the same ray of light is reflected (angle of reflection) in the following way.

Accept all reasonable hypothesis.

WHAT TO DO

You may work with other students in doing this activity. However, each person should record the data.

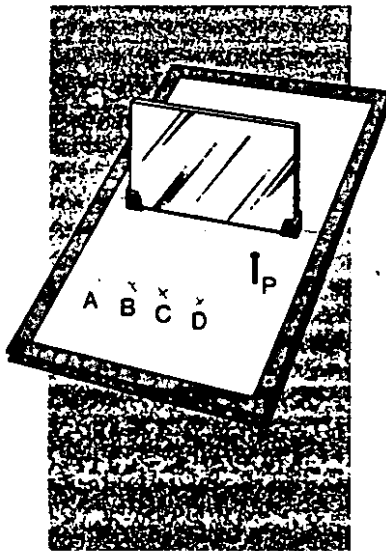

1. Tape a large sheet of paper to a large, flat piece of cardboard. Draw a line across the width of the paper. This line marks the position of the mirror and will be called the mirror line. Then attach the mirror support to the plane mirror and set the mirror on the mirror line. The reflecting surface of the mirror (the back side of a glass mirror) should be on the line. Mark the position of the mirror on the mirror line so that you can remove the mirror and put it back in exactly the same position.

2. Push a straight pin into the paper in front of the mirror. The pin should be stuck into the paper at a position (P) about ten centimeters from the mirror and toward the right-hand side of the paper. See the diagram.

3. Now make four pencil marks on the paper in front of the mirror and to the left of P. Label the marks A, B, C, and D (from left to right).

NAME _____

KEY

4. Stick a second pin into the paper at A . With one eye closed and with your head near the level of the top of the pin, look into the mirror and observe the image of the pin at P . Move your head so that the pin at A is in line with the image of the pin at P in the mirror. Keep the image in line with the pin at A and make a pencil mark on the paper directly in front of the mirror at the place where the image of the pin at P appears to be on the mirror.

5. Remove the pin at A and remove the mirror. Use the meter stick to draw a straight line starting from A , passing it through the mark you made in front of the mirror and extending it to the mirror line. Label the point on the mirror line A' . Now use the meter stick to draw a line from P to A' . The line from P to A' represents the path of a ray of light traveling from P to the mirror. The line from A' to A represents the path of the ray of light after it is reflected from A' to A .

6. Set the mirror on the mirror line again and repeat steps 4 and 5, using a pin stuck into the paper at B , at C , and then at D .

7. After drawing all the lines, use a protractor to measure the sizes of the angles made between each line you drew and the mirror line. Record these angles in the table below.

SAMPLE RESULTS

Angle	Measurement
Angle Between Line PA' and the Mirror Line	46°
Angle Between Line AA' and the Mirror Line	46°
Angle Between Line PB' and the Mirror Line	57°
Angle Between Line BB' and the Mirror Line	58°
Angle Between Line PC' and the Mirror Line	72°
Angle Between Line CC' and the Mirror Line	72°
Angle Between Line PD' and the Mirror Line	82°
Angle Between Line DD' and the Mirror Line	81°

ACTIVITY REVIEW Use the results you obtained to answer the following questions.

1. What do each of the points on the mirror line represent?

Each of the points on the mirror line represents a point at which reflection occurs.

2. How does the angle formed by line PA' and the mirror line compare with the angle formed by line AA' and the mirror line?

The two angles are equal.

3. How does the angle formed by line PB' and the mirror line compare with the angle formed by line BB' and the mirror line?

The two angles are nearly equal.

4. How does the angle formed by line PC' and the mirror line compare with the angle formed by line CC' and the mirror line?

The two angles are equal.

5. How does the angle formed by line PD' and the mirror line compare with the angle formed by line DD' and the mirror line?

The two angles are nearly equal.

6. Based on your results, how is the angle at which a ray of light hits a mirror related to the angle at which the ray of light is reflected?

The angle at which a ray of light hits a mirror is equal to the angle at which the ray of light is reflected.

NAME

Key

(Turn the page) 117

7. How do the results of this activity compare with your expected outcome?

Each student's response will depend upon the expected outcome stated at the beginning of this activity.

OPTIONAL The following activities are related to the activity you have just completed.

1. Obtain a convex mirror or a concave mirror. Support the mirror upright in some way. Try to measure the angles of incidence and reflection as you did for the plane mirror. What is the difficulty in measuring the angles?
2. Place a plane mirror at the bottom of an aquarium tank filled with water. Put a small amount of food coloring in the tank. Hold a flashlight above the tank at an angle so that the light reflects off the mirror and back up again. If you hold a protractor at the side of the tank, you should be able to measure the angles of incidence and reflection. Are the angles equal? Explain.
3. If possible, obtain some one-way glass. Try to find out how much light may be reflected with such glass. What happens to the light which is not reflected?
4. Obtain five plane mirrors and arrange them in a curve as shown on page 447 of your book. Using five flashlights, direct a beam of light at each of the mirrors. The beams should be parallel. What happens to the reflected light? Change the curvature of the five mirrors and direct the beams of light as before. What happens to the reflected light? In general, how do the angles of reflection for the first arrangement of mirrors compare to the angles of reflection for the second arrangement of mirrors? Explain.

Chapter 19

Use with Text Pages 546-550

REINFORCEMENT

● Wave Properties of Light

Fill in the blanks in this diagram of a light wave hitting a smooth, shiny surface.

FIGURE 1

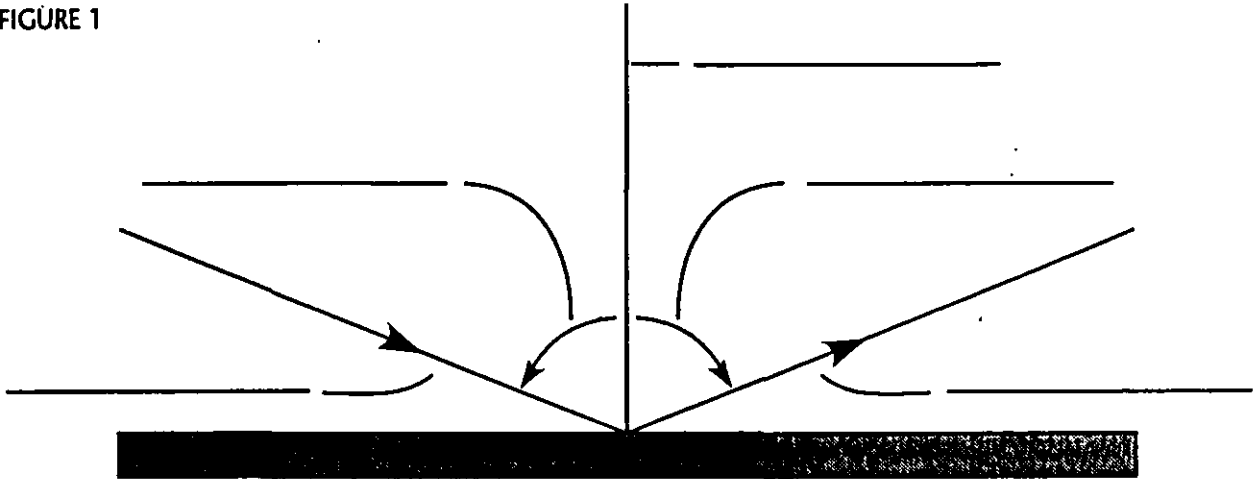
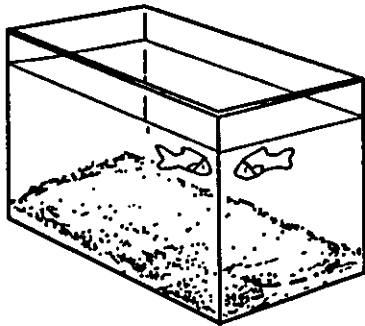

Figure 2 is a sketch of Tanya's fish tank as she looks at it from one of the corners. It appears to Tanya that there are two fish in the tank. However, she knows she has only one fish. Explain why two fish are seen and draw a ray diagram to show what happens. (Hint: The aquarium glass refracts light rays.)

FIGURE 2



On the blank, write the letter of the term that best completes each of the following statements.

- _____ 1. The interference of light shows the _____ behavior of light.
 a. particle b. translucent c. wave d. refraction
- _____ 2. The bending of light around corners is called _____.
 a. refraction b. diffraction c. interference d. reflection
- _____ 3. A(n) _____ is used to separate the colors of white light.
 a. diffraction grating c. photon
 b. electromagnetic spectrum d. modulation

Chapter 19

Use with Text Pages 546-550

REINFORCEMENT

● Wave Properties of Light

Fill in the blanks in this diagram of a light wave hitting a smooth, shiny surface.

FIGURE 1

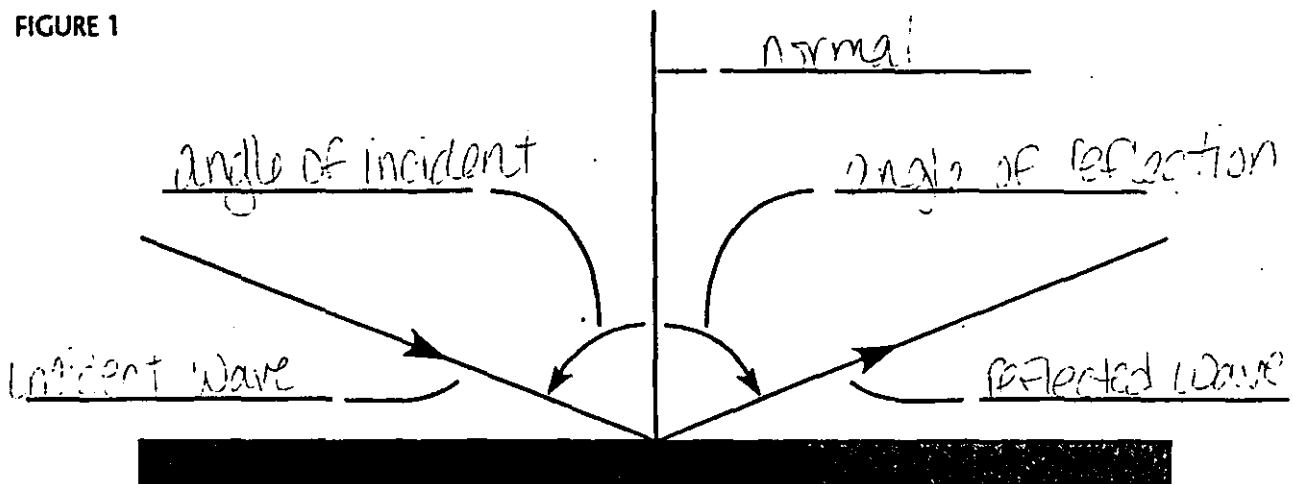
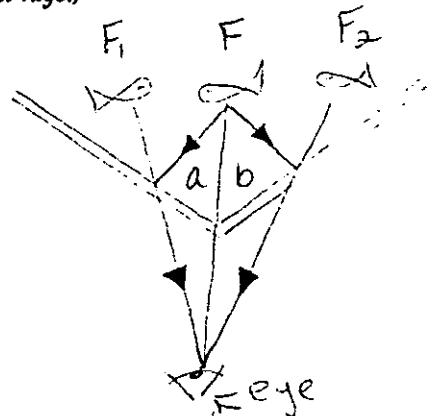
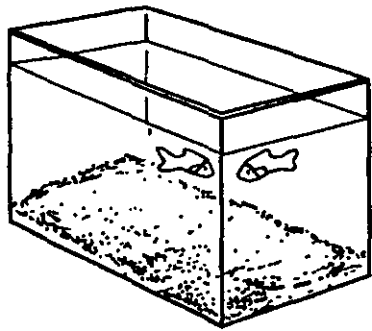

Figure 2 is a sketch of Tanya's fish tank as she looks at it from one of the corners. It appears to Tanya that there are two fish in the tank. However, she knows she has only one fish. Explain why two fish are seen and draw a ray diagram to show what happens. (Hint: The aquarium glass refracts light rays.)

FIGURE 2



Light rays a and b from the fish (F) are refracted producing two images that appear to come from F₁ and F₂.

On the blank, write the letter of the term that best completes each of the following statements.

- c 1. The interference of light shows the _____ behavior of light.
 a. particle b. translucent c. wave d. refraction
- b 2. The bending of light around corners is called _____.
 a. refraction b. diffraction c. interference d. reflection
- a 3. A(n) _____ is used to separate the colors of white light.
 a. diffraction grating c. photon
 b. electromagnetic spectrum d. modulation

Chapter 19

STUDY GUIDE

Use with Text Pages 546-550

● Wave Properties of Light

Use the words in the box to fill in the blanks.

incident	equal	reflection	incidence	reflected	normal	reflection
----------	-------	------------	-----------	-----------	--------	------------

When a wave strikes an object and bounces off, _____ occurs. Waves that strike an object are called _____ waves. Waves that bounce off are called _____ waves. A perpendicular line drawn from where the incident wave strikes is called the _____. The angle between the incident wave and the normal is the angle of _____. The angle between a reflected wave and a normal is the angle of _____. In reflection, the angles will be _____.

Label the diagram of a refracted light wave. Use the terms *incident wave*, *angle of incidence*, *refracted wave*, and *normal* to fill in the blanks. One term is used twice.

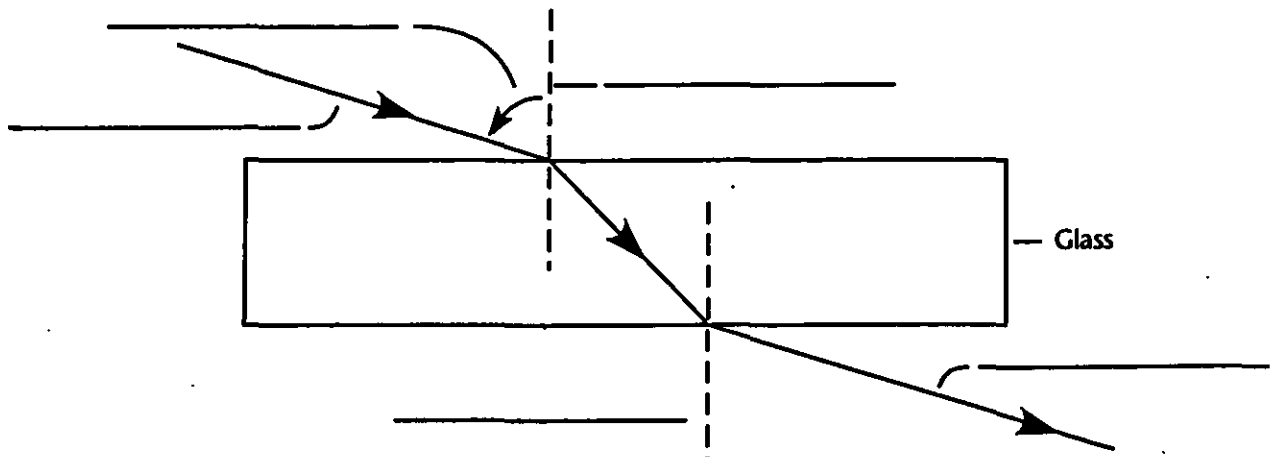

Use the words in the box to fill in the blanks.

interference	light	diffraction	slits	dark	colors	diffraction grating
--------------	-------	-------------	-------	------	--------	---------------------

The bending of light around corners is _____. Diffraction results in light and _____ areas on the edge of a shadow. Light or sound waves can meet, causing _____. If light is passed through narrow _____, the light waves will interfere, forming dark and _____ bands. When white light is passed through a _____, white light is separated into _____.

Chapter 19

Use with Text Pages 546-550

STUDY GUIDE

● Wave Properties of Light

Use the words in the box to fill in the blanks.

incident	equal	reflection	incidence	reflected	normal	reflection
----------	-------	------------	-----------	-----------	--------	------------

When a wave strikes an object and bounces off, reflection occurs. Waves that strike an object are called incident waves. Waves that bounce off are called reflected waves. A perpendicular line drawn from where the incident wave strikes is called the normal. The angle between the incident wave and the normal is the angle of incidence. The angle between a reflected wave and a normal is the angle of reflection. In reflection, the angles will be equal.

Label the diagram of a refracted light wave. Use the terms incident wave, angle of incidence, refracted wave, and normal to fill in the blanks. One term is used twice.

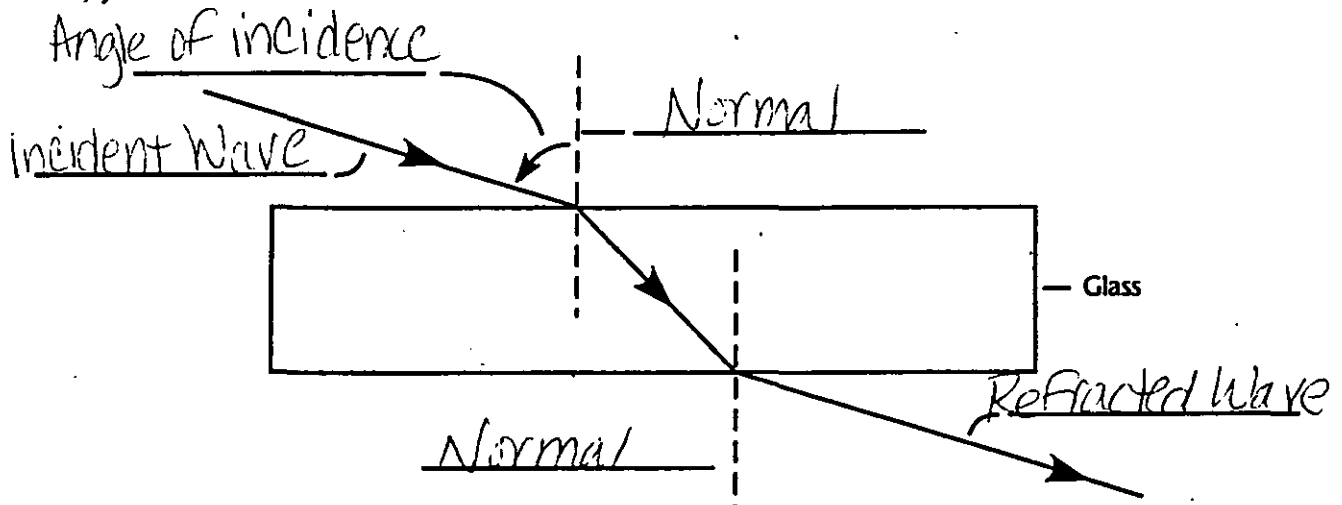

Use the words in the box to fill in the blanks.

interference	light	diffraction	slits	dark	colors	diffraction grating
--------------	-------	-------------	-------	------	--------	---------------------

The bending of light around corners is diffraction. Diffraction results in light and dark areas on the edge of a shadow. Light or sound waves can meet, causing interference. If light is passed through narrow slits, the light waves will interfere, forming dark and light bands. When white light is passed through a diffraction grating, white light is separated into colors.

Reflectivity of Light

Holly Rubach
Eighth Grade
Physical Science
03-10-00
10:25 a.m. – 11:10 a.m.

Materials: Macintosh or IBM-compatible computer, Serial Box Interface or ULI, Data Logger, Vernier Light Sensor, ring stand, utility clamp, white paper, black paper, 2 other pieces of colored paper, aluminum foil, *Reflectivity of Light* experiment sheet, Physics for Fun: Light video

Estimated Time: 45 minutes

State Goals: As a result of this lesson, students will have a working knowledge of the processes, techniques, methods, equipment, and available technology of science.

Lesson Objective: To identify the relationship between the color of an object and its reflectivity and then, to compare the reflectivity values for each color with aluminum foil, which has a reflectivity of 100 percent.

Introduction: White light can pass through some materials, such as air. But many materials reflect the waves of all or some of the colors in white light. The waves of colors that are not reflected are absorbed. The color of an object you see depends on which colors that object reflects and which colors it absorbs. A green leaf is green because it reflects mostly green light. It absorbs most of the waves of the other colors. A banana is yellow because it reflects mostly yellow light. What do you see when an object absorbs all colors? You see black. A black cat's fur absorbs almost all the white light that strikes it. What if an object reflects all colors? You see white. A polar bears' fur reflects almost all of the white light that strikes it. In today's lab we will be measuring the reflectivity of various colors. A mirror or shiny surface like aluminum foil should reflect 100 percent of the light; a black piece of paper will reflect little or none of the light.

Focusing Event: <Show the video clip that demonstrates how we see color.> Ask the students to describe how we see light. What color objects will have the highest reflectivity? What color objects will have the lowest reflectivity?

Instructional Procedures: <Hand out experiment sheets to the class.> Have all of the materials needed for each group at the center of each table. The students will work with the others at their table in groups of four. Read to the students the introduction and the procedures provided on the *Reflectivity of Light Experiment Sheet*. Have the students look at *Figure 1* to help with their set up. During the period the students will make observations and collect and record data. When all of the data has been collected the students are responsible for answering the questions in the processing the data section of the lab.

Check for Understanding: I will check to make sure the set-ups are correct for each group. I will help make any corrections needed. I will monitor the groups' progress by walking the room, answering questions, and keeping the students on task. Questions I may ask will be about the computer setup or what the students are observing during their experiment.

Guided Practice: The students will work on the section *Processing the Data* after all of the data has been collected. By looking at the answers I will be able to see if they understand the concept of the lab. If the students are off track, I will help them understand with cues and questioning techniques.

Independent Practice: For homework the students are responsible for answering the extension questions. The lab they will complete tomorrow will follow the theme in question one of the extensions section.

Closure: Today, we learned about the reflectivity of light. We discovered that different colors have different reflectivity values. What was the reflectivity of the aluminum foil? (100 percent.) What color paper had the greatest reflectivity value? (White.) What color had the lowest reflectivity value? (Black.) What are some colors with high reflectivity values? What are some colors with low reflectivity values? How might an astronomer use reflectivity to determine a planet's composition? For your homework tonight, you need to answer the extension questions at the end of the lab. They will be collected at the beginning of the period tomorrow.

Evaluation: The following factors will be considered to determine if the objective of this lesson plan was met: accuracy of values placed in the data table, accuracy of answers on the section *Processing the Data*, and reasonable attempt to answer *Extension* questions. The following rubric will be used to grade the assignment:

Task to be Completed	Number of Points Rewarded
Data Table	A data table with reasonable values is worth 5 points.
Questions 1-5 on <i>Processing the Data</i>	Each correct answer is worth 2 points for a total of 10 points for this section.
Question 1 and 2 on <i>Extension</i>	A reasonable attempt to answer the questions will earn the student 5 points.
Total number of points possible for this assignment	20

Note: Partial credit may be given for all three of the sections graded.

Grading Scale

A = 20-19 B = 18 C = 17-16 D = 15-14 F = 13 and below

Reflectivity of Light Pictures



Aaron and Brandon use a light sensor to calculate the percent reflectivity of the color green.

Reflectivity of Light Pictures



Emilia collects the Lux data on the computer while Daniel, Ashley, and Kevin calculate the percent reflectivity of the color yellow.

Reflectivity of Light Pictures

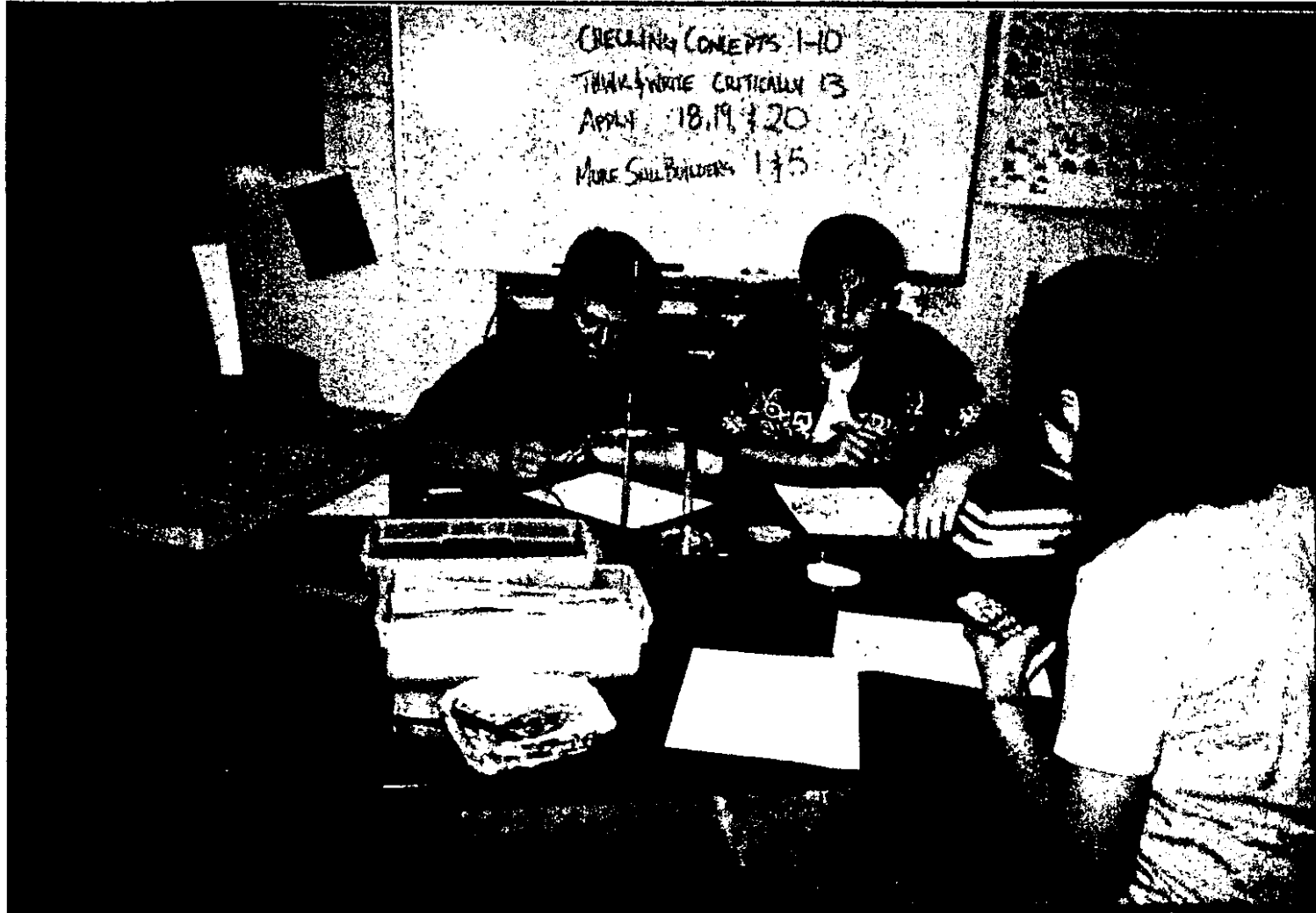

Jay, Zach, and Kori test the reflectivity of sand, soil, water, and salt to investigate the extension question.

Reflectivity of Light

Light is reflected differently from various surfaces and colors. An understanding of these differences is useful in choosing colors and materials for clothing, in choosing colors for cars, and in city planning. Astronomers use reflectivity differences to help determine characteristics of planets. In this experiment, you will be measuring the percent reflectivity (*albedo*) of various colors. You will measure reflection values from paper of various colors using a computer-interfaced light sensor and then compare these values to the reflection value of aluminum foil. The aluminum foil will arbitrarily be assigned a reflectivity of 100 percent. You will then calculate percent reflectivity using the relationship

$$\% \text{ Reflectivity} = \frac{\text{value for paper}}{\text{value for aluminum}} \times 100$$

OBJECTIVES

In this experiment, you will

- use a computer-interfaced light sensor to measure reflected light
- calculate percent reflectivity of various colors
- make conclusions using the results of the experiment

MATERIALS

Macintosh or IBM-compatible computer

Serial Box Interface or ULI

Data Logger

Vernier Light Sensor

white paper

black paper

2 other pieces of colored paper

aluminum foil

ring stand and utility clamp

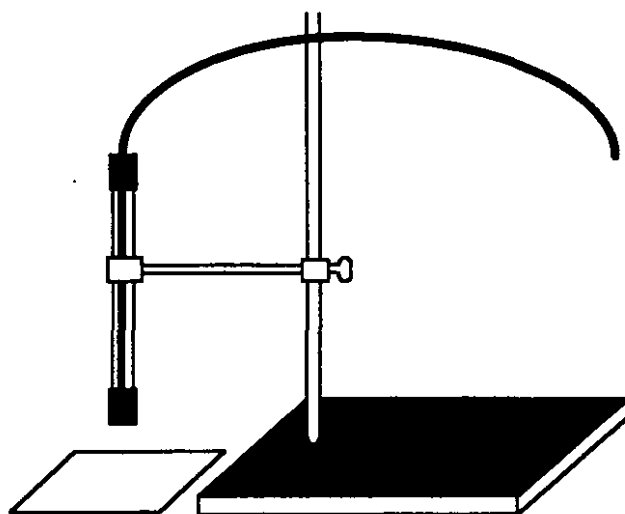

Figure 1

PROCEDURE

1. Use a utility clamp and ring stand to fasten a Light Sensor 5 cm from and perpendicular to a piece of colored paper as shown in Figure 1. The Light Sensor should be set on the 0-6000 Lux position. The classroom lights should be on.
2. Prepare the computer for data collection by opening "EXP23.LXP" from the *Physical Science with Computers* experiment files of Data Logger. Open the calibration file "EXP23.CLB".
3. When the reading stabilizes, record the color and the reflected light value (in Lux). The Lux is the SI unit for light illumination.
4. Make and record readings for aluminum, black, white, and two other colors.

DATA

Color	Aluminum	Black	White	_____	_____
Reflection Value (Lux)	_____	_____	_____	_____	_____

PROCESSING THE DATA

1. Calculate the percent reflectivity (albedo) of each color using the formula given in the introduction. Show your work and record the results in the table below.

Color	Aluminum	Black	White	_____	_____
Percent Reflectivity	<u>100%</u>	_____	_____	_____	_____

- Which color, other than aluminum, has the highest reflectivity?
- Which color has the lowest reflectivity?
- What materials might give a city or planet a high reflectivity or albedo? Explain.
- Does the planet Earth have high reflectivity? Why?

EXTENSIONS

- Design an experiment to test the reflectivity of sand, soil, water, and other materials.
- Design an experiment to determine if there is a relationship between reflected light and heat absorbed by various colors or materials.

**TEACHER INFORMATION
AND ANSWER KEY**

Reflectivity of Light

1. Equal-size pieces of construction paper and aluminum foil can be used and saved for reuse.
2. The procedure directs students to record reflectivity data from the large-window display (without clicking on the Start Button). Another possibility is to have students do a prompted (or keyboard) input for each of the 5 trials. The Data Logger file for this experiment is already set up for this option. Simply have your students click on the Start Button, click on Keep when the reading is stable, then enter a trial number of 1, 2, 3, 4, or 5.

Reflectivity of Light

Light is reflected differently from various surfaces and colors. An understanding of these differences is useful in choosing colors and materials for clothing, in choosing colors for cars, and in city planning. Astronomers use reflectivity differences to help determine characteristics of planets. In this experiment, you will be measuring the percent reflectivity (*albedo*) of various colors. You will measure reflection values from paper of various colors using a computer-interfaced light sensor and then compare these values to the reflection value of aluminum foil. The aluminum foil will arbitrarily be assigned a reflectivity of 100 percent. You will then calculate percent reflectivity using the relationship

$$\% \text{ Reflectivity} = \frac{\text{value for paper}}{\text{value for aluminum}} \times 100$$

OBJECTIVES

In this experiment, you will

- use a computer-interfaced light sensor to measure reflected light
- calculate percent reflectivity of various colors
- make conclusions using the results of the experiment

MATERIALS

Macintosh or IBM-compatible computer

Serial Box Interface or ULI

Data Logger

Vernier Light Sensor

white paper

black paper

2 other pieces of colored paper

aluminum foil

ring stand and utility clamp

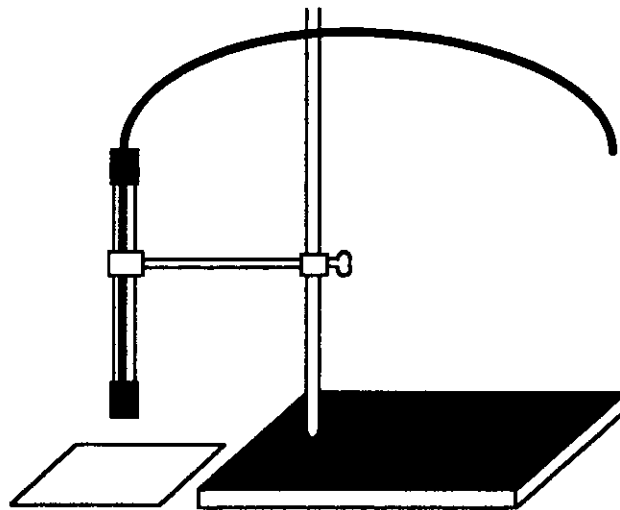

Figure 1

PROCEDURE

1. Use a utility clamp and ring stand to fasten a Light Sensor 5 cm from and perpendicular to a piece of colored paper as shown in Figure 1. The Light Sensor should be set on the 0-6000 Lux position. The classroom lights should be on.
2. Prepare the computer for data collection by opening "EXP23.LXP" from the *Physical Science with Computers* experiment files of Data Logger. Open the calibration file "EXP23.CLB".
3. When the reading stabilizes, record the color and the reflected light value (in Lux). The Lux is the SI unit for light illumination.
4. Make and record readings for aluminum, black, white, and two other colors.

DATA

Color	Aluminum	Black	White	Purple	Green
Reflection Value (Lux)	<u>737.7</u>	<u>231.2</u>	<u>582.2</u>	<u>326.9</u>	<u>425.1</u>

PROCESSING THE DATA

1. Calculate the percent reflectivity (albedo) of each color using the formula given in the introduction. Show your work and record the results in the table below.

Color	Aluminum	Black	White	Purple	Green
Percent Reflectivity	<u>100%</u>	<u>31.3</u>	<u>78.9</u>	<u>44.3</u>	<u>57.6</u>

2. Which color, other than aluminum, has the highest reflectivity?

White has the highest reflectivity.

3. Which color has the lowest reflectivity?

Black has the lowest reflectivity.

4. What materials might give a city or planet a high reflectivity or albedo? Explain.

Snow, ice, sand, and light colors would be expected to give a city or planet high reflectivity. The results of this experiment suggest that light colors reflect light best.

5. Does the planet Earth have high reflectivity? Why?

Planet Earth has high reflectivity because much of it is covered by snow, ice, sand, and water. The results of this experiment suggest that dark-colored parts of the earth, such as forests and green-crop land, would have lower reflectivity.

EXTENSIONS

1. Design an experiment to test the reflectivity of sand, soil, water, and other materials.
2. Design an experiment to determine if there is a relationship between reflected light and heat absorbed by various colors or materials.

Applying Reflectivity of Light

Holly Rubach
Eighth Grade
Physical Science
03-13-00
10:25 a.m. – 11:10 a.m.

Materials: Macintosh or IBM-compatible computer, Serial Box Interface or ULI, Data Logger, Vernier Light Sensor, ring stand, utility clamp, sand, soil, water, and other materials, aluminum foil, modified (Applying) *Reflectivity of Light* experiment sheet

Estimated Time: 45 minutes

State Goals: As a result of this lesson, students will have a working knowledge of the processes, techniques, methods, equipment, and available technology of science.

Lesson Objective: To discover the relationship between the color of an object and its reflectivity and then, to compare the reflectivity values for each color with aluminum foil, which has a reflectivity of 100 percent (i.e. in this experiment we will be testing the reflectivity of materials that make up the greater part of the Earth's upper crust).

Introduction: White light can pass through some materials, such as air. But many materials reflect the waves of all or some of the colors in white light. The waves of colors that are not reflected are absorbed. The color of an object you see depends on which colors that object reflects and which colors it absorbs. Many of the substances on Earth are highly reflective. Water, which makes up 70 percent of the Earth's crust, has a much higher reflectivity value than soil. Today we are going to be testing various materials found on Earth for their reflectivity values.

Focusing Event: Discuss results from the previous lab. Relate reflectivity of colors to the reflectivity of Earthly materials. Have the students hypothesize which materials will have a greater reflectivity.

Instructional Procedures: <Hand out experiment sheets to the class.> Remind the students that the lab we are completing today is just an extension of what we did during the previous lesson. Have all of the materials needed for each group at the center of each table. The students will work with the others at their table in groups of four. Read to the students the introduction and the procedures provided on the modified *Reflectivity of Light Experiment Sheet*. Have the students look at *Figure 1* to help with their set up. During the period the students will make observations and collect and record data. When all of the data has been collected the students are responsible for answering the questions in the processing the data section of the lab.

Check for Understanding: I will check to make sure the set-ups are correct for each group. I will help make any corrections needed. I will monitor the groups' progress by walking the room, answering questions, and keeping the students on task. Questions I may ask will be about the computer setup or what the students are observing during their experiment.

Guided Practice: The students will work on the section *Processing the Data* after all of the data has been collected. By looking at the answers I will be able to see if they understand the concept of the lab. If the students are off track, I will help them understand with cues and questioning techniques.

Independent Practice: For homework the students are responsible for completing the critical thinking worksheet *Light*.

Closure: Today, we continued to learn about the reflectivity of light. We discovered that different materials have different reflectivity values. Once again, what was the reflectivity of the aluminum foil? (100 percent.) What material had the greatest reflectivity value? What material had the lowest reflectivity value? What are some materials with high reflectivity values? What are some materials with low reflectivity values? How might an astronomer use reflectivity to determine a planet's composition? For your homework tonight, you need to complete the critical thinking worksheet, *Light*. It will be collected at the beginning of the period tomorrow.

Evaluation: The following factors will be considered to determine if the objective of this lesson plan was met: accuracy of values placed in the data table, accuracy of answers on the section *Processing the Data*, and accuracy of answers on the critical thinking worksheet. The following rubric will be used to grade the assignment:

Task to be Completed	Number of Points Rewarded
Data Table	A data table with reasonable values is worth 5 points.
Questions 1-5 on <i>Processing the Data</i>	Each correct answer is worth 2 points for a total of 10 points for this section.
Critical Thinking Worksheet, <i>Light</i>	Each question is worth 5 points for a total of 15 possible points.
Total number of points possible for this assignment	30

Note: Partial credit may be given for all three of the sections graded.

Grading Scale

A = 30-28 B = 27-26 C = 25-23 D = 22-21 F = 20 and below

Applying Reflectivity of Light

Light is reflected differently from various surfaces and colors. An understanding of these differences is useful in choosing colors and materials for clothing, in choosing colors for cars, and in city planning. Astronomers use reflectivity differences to help determine characteristics of planets. In this experiment, you will be measuring the percent reflectivity (*albedo*) of various materials found on earth. You will measure reflection values from materials of various colors and textures using a computer-interfaced light sensor and then compare these values to the reflection value of aluminum foil. The aluminum foil will arbitrarily be assigned a reflectivity of 100 percent. You will then calculate percent reflectivity using the relationship:

$$\% \text{ Reflectivity} = \frac{\text{value for paper}}{\text{value for aluminum}} \times 100$$

OBJECTIVES

In this experiment, you will

- use a computer-interfaced light sensor to measure reflected light
- calculate percent reflectivity of various earthly materials
- make conclusions using the results of the experiment

MATERIALS

Macintosh or IBM-compatible computer
Serial Box Interface or ULI
Data Logger
Vernier Light Sensor
white paper
black paper
2 other pieces of colored paper
aluminum foil
ring stand and utility clamp

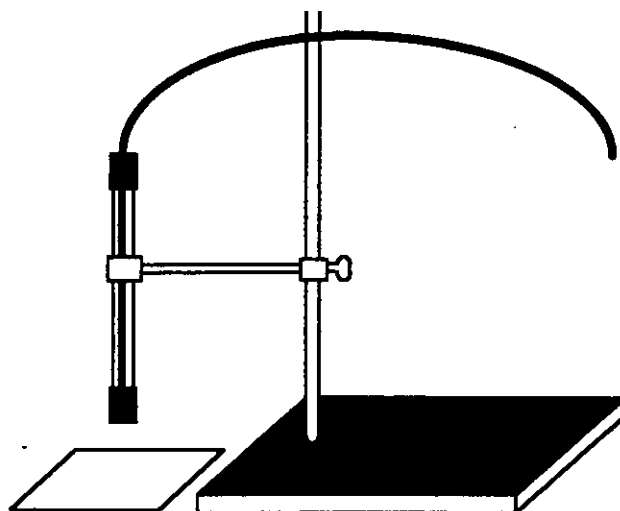

Figure 1

PROCEDURE

1. Use a utility clamp and ring stand to fasten a Light Sensor 5 cm from and perpendicular to a piece of colored paper as shown in Figure 1. The Light Sensor should be set on the 0-6000 Lux position. The classroom lights should be on.
2. Prepare the computer for data collection by opening "EXP23.LXP" from the *Physical Science with Computers* experiment files of Data Logger. Open the calibration file "EXP23.CLB".
3. When the reading stabilizes, record the color and the reflected light value (in Lux). The Lux is the SI unit for light illumination.
4. Make and record readings for aluminum, sand, soil, water, and other materials.

Name _____ Date _____

DATA

Material	Aluminum	Sand	Soil	Water	_____
Reflection Value (Lux)	_____	_____	_____	_____	_____

PROCESSING THE DATA

1. Calculate the percent reflectivity (albedo) of each material using the formula given in the introduction. Show your work and record the results in the table below.

Color	Aluminum	Sand	Soil	Water	_____
Percent Reflectivity	<u>100%</u>	_____	_____	_____	_____

2. Which material, other than aluminum, has the highest reflectivity?
3. Which material has the lowest reflectivity?

On questions 4 and 5 go into greater detail than you did on the previous lab.

4. What materials might give a city or planet a high reflectivity or albedo? Explain.
5. Does the planet Earth have high reflectivity? Why?

Chapter 19

CRITICAL THINKING

● Light

Communication Innovations

New fiber-optic telephone cables are winding their way among the starfish of the ocean floor. These state-of-the-art cables are capable of carrying up to 600 000 telephone conversations at once. They can also carry computer data and video signals on pulses of light. When the latest undersea fiber-optic cable system is finished, the entire globe will be linked.

A shortage of international telephone lines prompted the construction of these cables. Presently, many telephone companies lease expensive telephone circuits on communications satellites. However, the new cables have an advantage. Their state-of-the-art "repeaters" amplify the light pulses along their route of several thousand kilometers. They offer better sound quality than most satellite circuits, which receive and transmit signals from Earth—a round-trip of up to 80 000 km.

The current project has a price tag of more than a billion dollars. Although the initial cost of laying cable is high, this system may be less expensive than other alternatives in the long run. Satellites cannot be repaired easily and are expensive to build and launch. However, cables can interfere with the ocean ecosystem, and repairing them can be difficult.

Cellular phones are another communication innovation. However, cellular technology cannot be used for international communications. The range of a cellular phone is only about 1.5 km. Longer distances result in interference problems in the cellular signal. The signal would need to be carried across the ocean by some other signal-boosting method.

Shortwave radio is another method used for international communication. Shortwave radio waves must be reflected off the ionosphere. Communication can occur only if the atmospheric conditions are favorable.

Applying Critical Thinking Skills

1. How important to you is voice quality when using the telephone?

2. Based on voice quality, do you favor spending billions of dollars to lay fiber-optic cables under the oceans? Explain your answer.

3. What impact do you think the ocean cables will have on your phone bill?

Chapter 19

CRITICAL THINKING

● Light

Communication Innovations

New fiber-optic telephone cables are winding their way among the starfish of the ocean floor. These state-of-the-art cables are capable of carrying up to 600 000 telephone conversations at once. They can also carry computer data and video signals on pulses of light. When the latest undersea fiber-optic cable system is finished, the entire globe will be linked.

A shortage of international telephone lines prompted the construction of these cables. Presently, many telephone companies lease expensive telephone circuits on communications satellites. However, the new cables have an advantage. Their state-of-the-art "repeaters" amplify the light pulses along their route of several thousand kilometers. They offer better sound quality than most satellite circuits, which receive and transmit signals from Earth—a round-trip of up to 80 000 km.

The current project has a price tag of more than a billion dollars. Although the initial cost of laying cable is high, this system may be less expensive than other alternatives in the long run. Satellites cannot be repaired easily and are expensive to build and launch. However, cables can interfere with the ocean ecosystem, and repairing them can be difficult.

Cellular phones are another communication innovation. However, cellular technology cannot be used for international communications. The range of a cellular phone is only about 1.5 km. Longer distances result in interference problems in the cellular signal. The signal would need to be carried across the ocean by some other signal-boosting method.

Shortwave radio is another method used for international communication. Shortwave radio waves must be reflected off the ionosphere. Communication can occur only if the atmospheric conditions are favorable.

Applying Critical Thinking Skills

1. How important to you is voice quality when using the telephone?

Answers will vary from not important to very important.

2. Based on voice quality, do you favor spending billions of dollars to lay fiber-optic cables under the oceans? Explain your answer.

Yes - clarity and freedom from interference and noise are important; No - the present satellite-based service is inadequate.

3. What impact do you think the ocean cables will have on your phone bill?

Phone bills may go up to pay the initial costs of the cables. The bills may go down because the expense of the satellites will be stopped. The bills may initially go up, then go down as the initial investment is paid off.

Polarized Light

Holly Rubach
Eighth Grade
Physical Science
03-14-00
10:25 a.m. – 11:10 a.m.

Materials: Macintosh or IBM-compatible computer, Serial Box Interface or ULI, Data Logger, Vernier Light Sensor, ring stand, utility clamp, 2 Polaroid filters, *Polaroid Filters* experiment sheet, *Physical Science* video disc

Estimated Time: 45 minutes

State Goals: As a result of this lesson, students will have a working knowledge of the processes, techniques, methods, equipment, and available technology of science.

Lesson Objective: To study the effect Polaroid filters have on the transmission of light.

Introduction: Most light sources, such as incandescent lamps and the sun, emit light that vibrates in many directions. If this light passes through a special filter, called a polarizing filter, the light becomes polarized. A polarizing filter is made of chains of molecules in parallel rows that will transmit only light waves vibrating in the same direction as the molecular chains; in other words, the molecules act like parallel slits that allow only those light waves vibrating in one direction to pass through. Thus, polarized light is made up of transverse waves that vibrate only along one plane. When two polarizing filters are aligned so the molecular chains of one filter are oriented at right angles to the second filter, very little light or no light passes through. Polarizing filters are used over camera lenses to reduce glare in photographs, in sunglasses to reduce glare and reflections, and in 3-D glasses to create the impression of depth, or three dimensions. Today, in our lab, we will study the effect that Polaroid filters have on the transmission of light. We will use a computer to measure the intensity of transmitted light. The computer will generate a graphical representation of the change in light intensity during a 360 degree turn of a Polaroid filter that is on top of a second, fixed, Polaroid filter.

Focusing Event: <Show the videodisc clip that demonstrates the use of Polaroid filters.> Ask the students to describe the effect the filters had on incoming light. How did the orientation of the filters change the appearance of the incoming light? Where would such a device be useful? <Have the students read the section *Polarized Light* on pages 574 and 575 of their textbook.>

Instructional Procedures: <Hand out experiment sheets to the class.> Have all of the materials needed for each group at the center of each table. The students will work with the others at their table in groups of four. Read to the students the introduction and the procedures provided on the *Polaroid Filters Experiment Sheet*. Have the students look at

Figure 1 to help with their set up. During the period the students will make observations and collect and record data.

Check for Understanding: I will check to make sure the set-ups are correct for each group. I will help make any corrections needed. I will monitor the students to make sure they are on task. Questions I may ask will be about the computer setup or what the students are observing during their experiment.

Guided Practice: The students will work on the section *Processing the Data* after all of the data has been collected. By looking at the answers I will be able to see if they understand the concept of the lab. If the students are off track, I will help them understand with cues and questioning techniques.

Independent Practice: For homework the students are responsible for answering the extension question.

Closure: Today, we learned about Polaroid filters and how they can be used to filter light. We discovered that the waves of the filtered, or polarized, light vibrate in a specific direction. What is a common use of a polarizing material? (The lenses of sunglasses and 3-D glasses.) Describe what happens when the molecular chains of two filters are positioned so they are parallel to one another? (Light traveling in only one plane will pass through.) What happens when the molecular chains of two filters are positioned so they are perpendicular to one another? (Very little, if any, light will pass through.) Do sunglasses allow vertically or horizontally polarized light through to the eye? (Vertically polarized light.) Why are they made in such a way? (To block out most of the glare created from light being reflected off of horizontal surfaces, such as a lake or a car hood.)

Evaluation: The following factors will be considered to determine if the objective of this lesson plan was met: accuracy of data representation on the graph printout and accuracy of answers on the sections *Processing the Data* and *Extension*. The following rubric will be used to grade the assignment:

Task to be Completed	Number of Points Rewarded
Questions 1-5 on <i>Processing the Data</i>	Each correct answer is worth 2 points for a total of 10 points in this section.
Question 1 on <i>Extension</i>	A correct answer is worth 5 points for a total of 5 points for this section.
Graph	A graph that displays the appropriate results is worth 5 points for a total of 5 points for this section
Total number of points possible for this assignment	20

Note: Partial credit may be given for all three of the sections graded.

Grading Scale

A = 20-19 B = 18 C = 17-16 D = 15-14 F = 13 and below

Polaroid Filters

Polarized light is light in which the waves vibrate in a specific direction. It can be produced by passing light through a special "polarizing" filter. Sunglasses cut down glare on a bright sunny day. Some sunglasses have lenses made of polarizing material. The light waves that vibrate in the same plane as the polarizing material can pass through, but other waves are reflected or absorbed. In this experiment, you will use a computer-interfaced light sensor to study the transmission of light through Polaroid filters.

OBJECTIVES

In this experiment, you will

- use a computer to measure the intensity of transmitted light
- study the transmission of light by Polaroid filters

MATERIALS

Macintosh or IBM-compatible computer	ring stand
Serial Box Interface or ULI	utility clamp
Data Logger	2 Polaroid filters
Vernier Light Sensor	

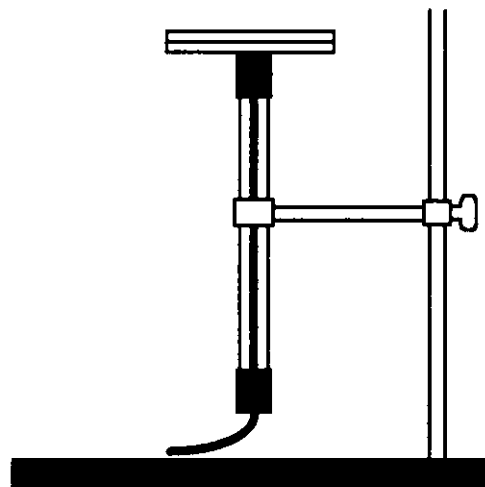

Figure 1

PROCEDURE

1. Use a utility clamp to fasten a Light Sensor to a ring stand as shown in Figure 1. The tip of the Light Sensor should point up. Make sure the Light Sensor's switch is set to the 0-600 Lux position.
2. Place two Polaroid filters together. Look at the room lights through the filters. While holding one filter in place, turn the other filter. Record your observations.
3. Prepare the computer for data collection by opening "EXP24.LXP" from the *Physical Science with Computers* experiment files of Data Logger. Open the calibration file "EXP24.CLB". The vertical axis will have illumination scaled from 0 to 300 Lux. The horizontal axis will have time scaled from 0 to 60 seconds.
4. Position the Polaroid filters on top of the Light Sensor as shown in Figure 1. Click on the Start button to begin data collection. Hold the bottom filter still and slowly turn the top filter one complete turn. Hold the filter edges so you do not block the light coming from above. As the turn is completed, click on the Stop button to end data collection. Make sure you complete the rotation while the program is collecting data.
5. Choose Auto Scale on the Display menu, then examine your graph. If you turned the top polarizing filter unevenly, you may want to repeat Step 4.
6. Choose Print Graph from the File menu and print the graph.

OBSERVATIONS

PROCESSING THE DATA

1. Describe your graph.
2. How many crests (maximums) does the graph have? How many troughs (minimums)?
3. There are 360 degrees in a complete turn. How many degrees did you turn the Polaroid filter to cause the light intensity to go from a maximum value (crest) to a minimum value (trough)? To go from a minimum value to a maximum value?
4. Light is partly polarized when reflected from some flat surfaces, such as water. Why are Polaroid sunglasses especially effective in such conditions?
5. Summarize what you have learned about Polaroid filters in this experiment.

EXTENSION

1. Explain your answers to Question 3.

**TEACHER INFORMATION
AND ANSWER KEY**

Polaroid Filters

1. If you do not have polarizers, old Polaroid sunglass lenses will work well. Polarizers are available in most science catalogs.
2. If there are no markings on the polarizers, place a felt-tip pen mark near the edge of each to serve as a reference point.
3. If you do not have printers available, consider having your students sketch the graph instead of printing it.
4. The intensity of the light transmitted by the two filters varies according to the law of Malus. Refer to a college physics text for more background information.

Polaroid Filters

Polarized light is light in which the waves vibrate in a specific direction. It can be produced by passing light through a special “polarizing” filter. Sunglasses cut down glare on a bright sunny day. Some sunglasses have lenses made of polarizing material. The light waves that vibrate in the same plane as the polarizing material can pass through, but other waves are reflected or absorbed. In this experiment, you will use a computer-interfaced light sensor to study the transmission of light through Polaroid filters.

OBJECTIVES

In this experiment, you will

- use a computer to measure the intensity of transmitted light
- study the transmission of light by Polaroid filters

MATERIALS

Macintosh or IBM-compatible computer
Serial Box Interface or ULI
Data Logger
Vernier Light Sensor

ring stand
utility clamp
2 Polaroid filters

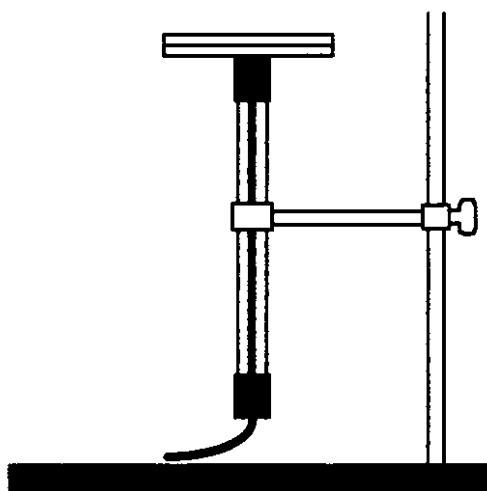
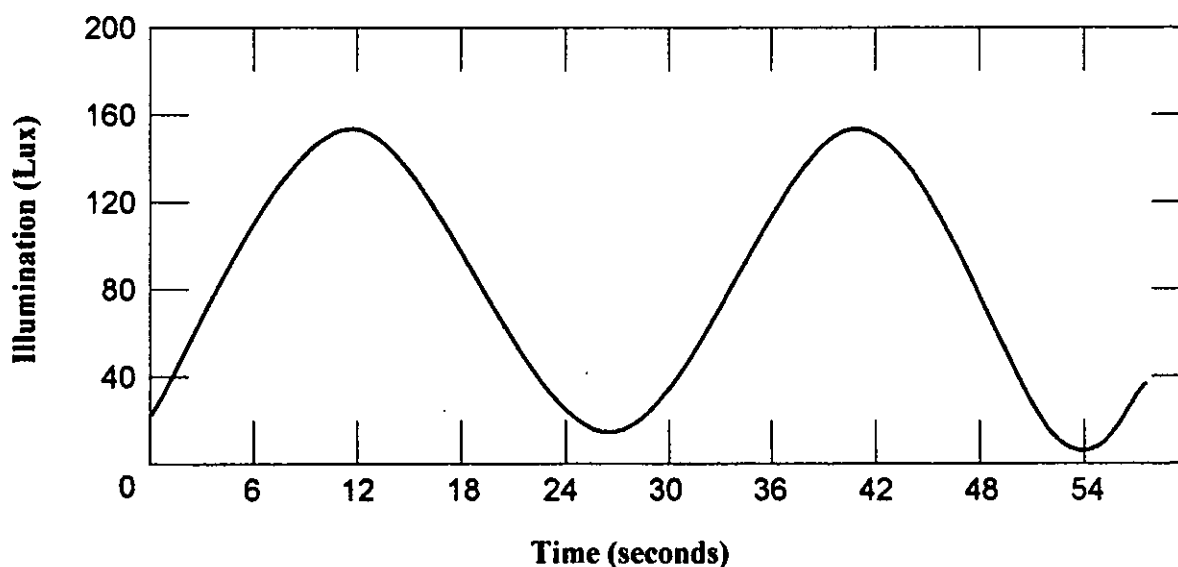

Figure 1

PROCEDURE

1. Use a utility clamp to fasten a Light Sensor to a ring stand as shown in Figure 1. The tip of the Light Sensor should point up. Make sure the Light Sensor's switch is set to the 0-600 Lux position.
2. Place two Polaroid filters together. Look at the room lights through the filters. While holding one filter in place, turn the other filter. Record your observations.
3. Prepare the computer for data collection by opening "EXP24.LXP" from the *Physical Science with Computers* experiment files of Data Logger. Open the calibration file "EXP24.CLB". The vertical axis will have illumination scaled from 0 to 300 Lux. The horizontal axis will have time scaled from 0 to 60 seconds.
4. Position the Polaroid filters on top of the Light Sensor as shown in Figure '1. Click on the Start button to begin data collection. Hold the bottom filter still and slowly turn the top filter one complete turn. Hold the filter edges so you do not block the light coming from above. As the turn is completed, click on the Stop button to end data collection. Make sure you complete the rotation while the program is collecting data.
5. Choose Auto Scale on the Display menu, then examine your graph. If you turned the top polarizing filter unevenly, you may want to repeat Step 4.
6. Choose Print Graph from the File menu and print the graph.

OBSERVATIONS

PROCESSING THE DATA

1. Describe your graph.

The graph is a curve with two maximums and two minimums. (See the previous example.)

2. How many crests (maximums) does the graph have? How many troughs (minimums)?

The graph has two crests and two troughs.

3. There are 360 degrees in a complete turn. How many degrees did you turn the Polaroid filter to cause the light intensity to go from a maximum value (crest) to a minimum value (trough)? To go from a minimum value to a maximum value?

A turn of 90° causes the light intensity to go from a maximum value to a minimum value. The light intensity also goes from a minimum value to a maximum value with a turn of 90° .

4. Light is partly polarized when reflected from some flat surfaces, such as water. Why are Polaroid sunglasses especially effective in such conditions?

Polaroid sunglasses block much of the partially-polarized light reflected from such flat surfaces, thus reducing glare.

5. Summarize what you have learned about Polaroid filters in this experiment.

Answers will vary.

EXTENSION

1. Explain your answers to Question 3.

Unit Review

Holly Rubach
Eighth Grade
Physical Science
03-15-00
10:25 a.m. – 11:10 a.m.

Materials: Science Discovery: Science Sleuths videodisc and resource manual, transparency with the questions and answers to the textbook's chapter review, transparency of rubric for Light Unit Exam, and for each student, a copy of the chapter review worksheets and a copy of the *Science Sleuths Lab Report*

Estimated Time: 45 minutes

State Goals: As a result of this lesson, students will have a working knowledge of the concepts and basic vocabulary of biological, physical, and environmental sciences and their application to life and work in the contemporary technological society.

Lesson Objective: To reinforce the objectives for this unit by relating the ideas expressed in the textbook with the concepts we learned in the labs and then applying them to real life situations.

Introduction: Today we are going to use this unit's handouts, labs, and textbook assignments to review for tomorrow's exam. We are going to use the knowledge we have gained during this unit to creatively solve a real life problem.

Instructional Procedures: This lesson will serve as a review for Chapter 19. You should have completed the chapter review from the textbook for today. Trade your spiral notebook with your neighbor; we are going to grade your answers. <Show transparency and discuss answers with students.> Mark the number the person got correct out of 40 and hand the spiral back to its owner. <Record scores.> <Hand out the *Science Sleuths Lab Reports* to the class.> Now we are going to try an activity to test what you have learned in the past two weeks. I am going to show you some clues to a mystery, and you will make observations on your lab sheet. When you think you have a solution to the mystery, write it in the space provided on the lab sheet. <Show *Fogged Photos* mystery.> When the activity is completed have the students turn in their completed lab sheets. Go over their findings. <Hand out the chapter review worksheets.> In the remaining time you need to work on these worksheets. They will help you on the exam tomorrow.

Check for Understanding: I will check to make sure that the students are paying attention and following directions. I will help make any corrections needed. I will monitor the students to make sure they are on task. Questions I may ask will be about what they have learned during the Light Unit to direct them towards possible solutions to the *Fogged Photos* mystery.

Guided Practice: The students will participate in the *Fogged Photos* mystery. Each of the students will be required to complete the handout that accompanies the video. By looking at the possible solutions that the students generate I will be able to see if they understand the concepts we have been covering during this unit. If the students are off track, I will help them understand with cues and questioning techniques.

Independent Practice: For homework the students are responsible for completing the chapter review worksheets.

Closure: Today, we have reviewed the concepts and theories of the Light Unit. Tomorrow, you will have an exam to assess your progress in this subject. Bring a pencil, your spiral notebook, and the labs and handouts for this unit; you will be able to use them to help you on the exam. If you come tomorrow with tonight's homework assignment completed correctly, you will receive 20 extra credit points that will count towards your exam's final score. The sections on the exam are broken down as seen on this transparency. <Show transparency.>

Evaluation: The following factors will be considered to determine if the objective of this lesson plan was met: textbook chapter review, *Science Sleuths Lab Report*, and the chapter review worksheets. The following rubric will be used to grade the assignment:

Task to be Completed	Number of Points Rewarded
Textbook Chapter Review	Each correct answer is worth 1 point for a total of 40 points
<i>Science Sleuths Lab Report</i>	Labs will graded subjectively; if it is evident that the student made a concerted effort the all of the 20 possible points will be awarded
Chapter Review Worksheets	Correctly completed worksheets are worth 20 extra credit points. For every incorrect or missing answer one point will be subtracted from the 20.
Total number of points possible for these assignments	60 + 20 bonus points

Note: Partial credit may be given for all three of the sections graded.

Grading Scale

A = 60-56 B = 55-52 C = 51-46 D = 45-42 F = 41 and below

Reviewing Vocabulary

1. transverse wave produced by the motion of electrically charged particles
 2. bundle of radiation with no mass
 3. electromagnetic radiation that is felt as heat
 4. object that can't be seen through
 5. light produced by a heated filament
 6. occurs when a wave strikes an object and then bounces off
 7. the bending of waves around a barrier
 8. contains many parallel slits that can separate white light into colors
 9. highest frequency electromagnetic wave
 10. radio wave with the greatest energy
- 1-c 2-k 3-g 4-j 5-f 6-n 7-a 8-b 9-e 10-h**
- a. diffraction
 - b. diffraction grating
 - c. electromagnetic radiation
 - d. fluorescent light
 - e. gamma ray
 - f. incandescent light
 - g. infrared radiation
 - h. microwave
 - i. modulation
 - j. opaque material
 - k. photon
 - l. pigment
 - m. radio wave
 - n. reflection refraction
 - o. translucent material
 - p. transparent material
 - q. ultraviolet radiation
 - r. visible radiation
 - s. X ray

Checking Concepts

- Electromagnetic waves are different from other types of wave in that they do not _____.
a. have amplitude c. transfer energy
b. have frequency d. need a medium
- When light enters matter, it _____.
a. slows down b. speeds up
c. travels at 300 000 km/s
d. travels at the speed of sound
- A contact lens is _____.
a. transparent c. opaque
b. translucent d. square
- Electromagnetic waves with the longest wavelengths are _____.
a. radio waves c. X rays
b. visible light d. gamma rays
- The process of changing the frequency or amplitude of radio waves in order to encode a signal is _____.
a. diffraction c. reflection
b. modulation d. refraction
- When food molecules absorb microwaves, they vibrate faster and their _____.
a. kinetic energy decreases
b. kinetic energy increases
c. temperature decreases
d. temperature remains constant
- Your body gives off _____.
a. radio waves c. infrared radiation
b. gamma rays d. ultraviolet radiation
- Fluorescent bulbs glow when the phosphors inside absorb _____.
a. microwaves c. infrared radiation
b. gamma rays d. ultraviolet radiation
- X rays are best absorbed by _____.
a. bone c. muscle
b. hair d. skin
- Objects that partially scatter light that passes through them are called _____.
a. reflective c. translucent
b. opaque d. transparent

1-d 2-a 3-a 4-a 5-b 6-b 7-c 8-d 9-a 10-c

Understanding Concepts

11. Explain how sound waves are converted to radio waves. Give some examples.

Sound waves are converted to electrical signals that correspond to the sound's characteristic patterns. These signals can then be used to modulate, or vary, either the amplitude or frequency of a radio wave. This is done in radio and TV transmissions, cellular phones, and cordless phones.

12. What is the difference between light color and pigment color?

Light color is determined by the wavelength of light transmitted, while pigment color is determined by the color of light reflected.

13. How is the reflection of light off a white wall similar to the reflection of light off a mirror? How is it different?

Light reflects off a white wall or a mirror because of the law of reflection. Both the wall and mirror reflect all light frequencies. Light reflected off a wall is scattered because the surface is rough; light reflected off a mirror is not scattered.

Understanding Concepts (cont.)

14. Explain which property of light helps produce a rainbow.

Rainbows are produced when white light from the sun passes through droplets of water suspended in the atmosphere after a rain. The water droplets act as prisms, refracting light.

15. Describe the wave model of light and note one of the scientists who studied it.

Light can be bent around barriers and diffracted to show interference patterns. This suggests that light behaves as a wave. Light's wavelike behavior was studied by Francesco Grimaldi and Thomas Young.

Thinking Critically

16. Heated objects often give off light of a particular color. Explain why an object that glows blue is hotter than one that glows red.

Blue light has a higher frequency than red light, so its particles carry more energy. The hotter an object is, the more energy it gives off.

17. How would a blue shirt appear if a blue filter were placed in front of it? A red filter? A green filter?

A blue filter transmits the blue light reflected from the shirt, and the shirt appears blue. Because the red and green filters each absorb blue light, the shirt appears black.

18. Use the law of reflection to explain why you see only a portion of the area behind you when you look into a mirror.

You can see only areas whose images are reflected from the mirror into your eyes. Other areas behind you are reflected at angles that prevent the images from entering your eyes.

Thinking Critically (cont.)

19. Which color of light changes speed the most when it passes through a prism?
Explain.

Violet, because it is bent the most by a prism. The greater the difference in the speed of light in two different media, the more it is refracted.

20. Explain why you can hear a fire engine coming around a street corner before you can see it.

Waves with longer wavelengths are diffracted more easily than waves with shorter wavelengths. Sound has a much longer wavelength than light, and is therefore bent more easily around a street corner.

Resources

Observations/Notes

Resources	Observations/Notes

Summary Findings

Recommendations for Further Action/Study



FOGGED PHOTOS

Sleuth Resource
Guidebook

B10



1. SCENE SET: Observatory director
37145
(play)



2. Astronomer
37609
(play)
3. City engineer
38500
(play)
4. News report on toxic spill near nuclear power plant
39047
(play)



Date	Comments
4/1	position 00400n4100, 8"x10", wide shot photo, M31, Andromeda Galaxy
4/2	position 00400n4100, 8"x10", long exposure, photo of M31, Adromeda Galaxy
4/3	same
4/5	same
4/8	same
4/10	same
4/11	8x10", short exposure photo, Earth's moon
4/12	same
4/15	position 00400n4100, 8"x10", long exposure, M31, Andromeda Galaxy, dwarf galaxies
4/23	same

5. Observatory log
40046
(step)



6. Search on the words AIRPORT, CAREY COUNTY, LIGHTING, HIGHWAY, OBSERVATORY, SPILL, X-RAYS
40049
(step)





7. Article #1

40052

(step)



The X-ray Machine and You

by Tomasina Nagrin

The X-ray machine is a major part of an airport's security system, and I, for one, am glad it's there. However, I don't send my film through the machine; I hand the camera and the exposed film to a security guard. Under most circumstances, the X-ray machine at the airport won't hurt film, but if you're on a trip, taking a lot of different planes, sending those pictures through a lot of different airport security systems, your pictures are in trouble. Fast film is in trouble with only one trip through the machine. The pic-

tures will have a greenish fog and no contrast.

X-rays are on the light spectrum, even though we can't see them. Our film, which has been designed to react to light, reacts to the X-rays.

In film specifically made for X-rays, dyes react to the X-ray radiation portion of the spectrum only. When an X-ray of your chest is taken, the rays pass quickly through the soft portion of your flesh and organs, and are slowed down by the density of your bones. The slowed-down rays form the picture of your ribs on the X-ray. The same thing happens when X-rays pass through your luggage; metal objects slow down the rays and appear on the monitor.

Traveler's Digest, the Magazine of Newport Airlines



9. Article #3

40058

(step)



Council Member Proposes New Lights

Carey Town News

Council member Jason Fitzgerald proposed at the monthly meeting of Carey County Council that the county invest in high pressure sodium lights in order to take advantage of their efficiency. Mr. Fitzgerald explained that a 50 watt high-pressure sodium bulb illuminates with the same incandescence as a 250 watt regular bulb and lasts up to 24 times as long.

The low-pressure sodium bulbs were unpleasant to use because they had a bad effect on color. The newer, high-pressure versions boast a light quality equal to standard bulbs. The major drawback to the purchase is the cost. Although they are purported to save money due to their efficiency, high-pressure sodium lights will be enormously expensive initially.



8. Article #2

40056



Ammonia Spill on Highway 61

Challis Express

Fire fighters identified the fluid that was leaking from an overturned container truck on

Highway 61 near the Trumand Nuclear Power Plant as ammonia. The driver of the vehicle refused to identify the substance, leading investigators to fear that it might be an even more harmful substance. Tests revealed its identity. The driver had failed to notify the state police that he was driving hazardous material through the area.



◀ STEP REVERSE



PLAY ▶



STEP FORWARD ▶▶



10. Article #4

40061



Lights Cast a Shadow

Freeville Free Press

In an effort to economize, the managers of Freeville Mall switched to low-pressure sodium lights. Shoppers and shopkeepers are now complaining about the lights, saying that they make everybody look sick. Bonnie Harry, the owner of the Pearl Boutique, blamed the lights for a decline in sales, saying that nobody wants to buy clothes because everything they try on looks terrible under the lights.



11. Schematic diagram of telescope

40063



12. Current map of the area

40065



13. 10-year-old map of area

40067



14. 25-year-old map of area

40069

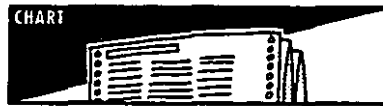

15. Precipitation table

40071

(step)



Precipitation for
Carey Co.
February

Day	Precip. (in)
1	-
2	-
3	.23
4	.5
5	-
6	-
7	-
8	-
9	-
10	-
11	.12
12	-
13	-
14	-
15	-
16	.18
17	.32
18	-
19	-
20	-
21	-
22	-
23	-
24	-
25	-
26	-
27	-
28	-

Precipitation for
Carey Co.
March

Day	Precip. (in)
1	-
2	-
3	-
4	-
5	.38
6	-
7	-
8	-
9	-
10	-
11	.24
12	-
13	-
14	-
15	-
16	-
17	-
18	-
19	-
20	-
21	-
22	-
23	-
24	-
25	-
26	.39
27	-
28	-
29	-
30	-
31	-

Precipitation for
Carey Co.
April 1-23

Day	Precip. (in)
1	-
2	-
3	-
4	.21
5	-
6	-
7	-
8	-
9	.43
10	-
11	-
12	-
13	-
14	-
15	-
16	.18
17	-
18	-
19	-
20	-
21	-
22	-
23	-

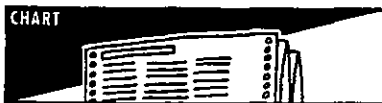

16. Lunar phase chart for past year
40075



New	1st Qt.	Full	Last Qt.
-	-	-	Jan. 7
Jan. 15	Jan. 23	Jan. 30	Feb. 6
Feb. 14	Feb. 21	Feb. 28	Mar. 8
Mar. 16	Mar. 23	Mar. 30	Apr. 7
Apr. 14	Apr. 21	Apr. 28	May 7
May 14	May 20	May 28	Jun. 5
Jun. 12	Jun. 19	Jun. 27	Jul.5
Jul. 11	Jul. 18	Jul. 26	Aug. 3
Aug. 10	Aug. 17	Aug. 25	Sep. 1
Sep. 8	Sep. 15	Sep. 23	Oct. 1
Oct. 7	Oct. 15	Oct. 23	Oct. 20
Nov. 6	Nov. 14	Nov. 21	Nov. 28
Dec. 6	Dec. 14	Dec. 21	Dec. 28



19. Visible light spectrum

40085

(step)



Note From: Cheryl

Subject: Visible light spectrum

This is a physics definition; an artist might have something different to say.

Definition: that part of the electromagnetic spectrum to which the human eye is sensitive. The wavelengths range from c 400 to c 750 nanometers. When white light (which contains all wavelengths) is separated into a spectrum, each wave length is seen to correspond to a different color.



17. Electromagnetic spectrum chart
40077



18. Emmission spectra of various lights
40079
(step)



◀ STEP REVERSE



PLAY ▶



STEP FORWARD ▶▶



20. Radar
40088
(step)



Note From: Cheryl
Subject: Radar

"Radar" is an acronym for
RAdio Detection And Ranging.
Get it?

Definition: A system for detect-
ing the position and motion of an
object by the use of radio waves
reflected from the surface of the
object.

Radar systems transmit pulses
of electromagnetic waves by
means of directional antennas.
Any object in the path of the
waves reflects some of the waves
back to the transmitting unit,
which then transforms the rays
into images on a cathode-ray
tube. The frequency of radar
waves is measured in megahertz;
one megahertz equals one mil-
lion hertz (cycles per second).
Radio waves have lower fre-
quencies than light waves.

Most radar systems operate at
frequencies of about 1 to 50,000
megahertz. Optical radars oper-
ate at much higher frequencies.
Some generate light waves with
frequencies up to 1 billion mega-
hertz.



21. Recent observatory photo
40092
(step)



22. Last year observatory photo
40094



23. Recent short exposure photo
40096



24. Photo taken with dirty lens
40098



25. Photo taken with a jerky tele-
scope motor
40100



26. Photo taken with old film
40102



27. Light leak test
40104





THE FOGGED PHOTOS

Teacher's Manual for the Science Sleuths Videodisc

B10

KEY CONCEPT

Different light sources produce different electromagnetic emission spectra; light pollution can be a problem for earth-based astronomers.

SUMMARY

For the past three months, the photographs taken at an observatory have been fogged. The director of the observatory suspects that the new camera is flawed.

MISSION

Determine why the photographs are fogged.

SOLUTION

A wealthy suburb near the observatory has replaced its low-pressure sodium lights with high-pressure sodium lights. High-pressure sodium lights emit light that covers such a wide range of the electromagnetic emission spectrum that filtering, a technique used to deal with narrow emission spectra, is not possible.

TEACHER'S NOTES

1. SCENE SET: Observatory director

Clues: For the past three months, the photographs taken from the observatory are foggy, regardless of the weather; the telescope is not flawed.

Distractors: Camera

Discussion: Discuss possible causes of fogged photographs: possibilities include problems with the camera, the film, the telescope, the weather. View and compare different photo tests. See other interviews; schematic of telescope; read observatory log.

2. Astronomer

Clues: 12 years ago, mercury vapor lights caused a similar problem: they cover a wide range of the light spectrum. The problem was cured when town switched to sodium vapor lights that have a band of wave lengths narrow enough to filter; town has grown; fogging worse with longer exposure

Distractors: Bad film

Discussion: View the chart of the electromagnetic spectrum: which are familiar? Check the emission spectra of various lights: note the differences between the low-pressure sodium vapor light and the mercury vapor light. Compare recent photos with last year's photos; short exposure photo with recent exposure; comparison photos taken with new and old film; check light leak test; Sleuth Info on visible light.

3. City engineer

Clues: Town has grown; some communities switching high-pressure sodium lights

Distractors: Electricity used by new lights; radar

Discussion: Discuss how a growing town might affect an observatory: why are most observatories built away from towns?

This engineer is not too bright; note that he thinks high-pressure sodium vapor lamps will cost more to operate. The main reason high-pressure sodium vapor lights are used is that they are more efficient than low-pressure sodium lights. Their initial cost is higher, but they last longer and use far less electricity.

Compare this interview with that of the astronomer. Note that both mention sodium vapor lights; check emission spectra of various lights. Check Sleuth Info on radar and emission spectra; current and previous maps of the area; literature search reveals articles on lighting in the area.

4. News report on toxic spill near nuclear power plant

Clues: None

Distractors: Nuclear power plant

Discussion: Neither the fact that there has been a toxic spill nor the fact that it happened near a nuclear power plant should have any affect on the observatory's film. A literature check confirms that the toxic spill was not a substance that would affect film. Review emission spectra chart.

5. Observatory log

Clues: Fogging over past three months

Discussion: This confirms that there is no correlation between the weather and their fogging problems. The log shows no correlation between anything and the fogging problems. Confirm by checking precipitation table and lunar phase chart. They are not having problems with the moon or precipitation, including fog.

6. Literature Search

Discussion: Articles #1 and 3 provide helpful information.

7. Article #1 ("The X-ray Machine and You")

Clues: Film reacts to emissions from the light spectrum, even non-visible light

Distractors: X-rays cast a green fog on film in cameras.

Discussion: This article doesn't directly explain the observatory's problems, but provides an analogous discussion of how emissions from different parts of the light spectrum can fog film. Review the chart of the electromagnetic spectrum; recent observatory photos.

8. Article #2 ("Ammonia Spill on Highway 61")

Clues: None

Distractors: Nuclear power plant; ammonia

Discussion: Neither the ammonia nor the nuclear power plant are causing the fogging problems. Radiation could affect film; but this accident only affected the highway.

9. Article #3 ("Council Member Proposes New Lights")

Clues: Proposal to switch to high-pressure sodium lights

Distractors: Low-pressure sodium lights have a bad effect on color.

Discussion: This article delineates differences between high- and low-pressure sodium lights. From now on, note which kind of sodium vapor lights are being referred to. Review interviews with astronomer and engineer; emission spectra of various lights; check other literature. Note that the actual visible quality of the lights is different. View maps of the area: locate areas mentioned in the interviews and the articles.

10. Article #4 ("Lights Cast a Shadow")

Clues: Low-pressure sodium lights are unattractive

Discussion: More confirmation that low-pressure sodium vapor lights are different. Discuss reasons for using different kinds of lights; include quality, efficiency, durability, and long- and short-term costs. Review emission spectra of various lights.

11. Schematic diagram of telescope

Clues: None

Discussion: Illustrates the telescope in question. This type of telescope can be used for direct viewing or for shooting photographs. Sometimes a public observatory will hook a video camera to the eyepiece, so spectators can all view together.

12. Current map of area

Clues: Belle View nearby

Distractors: Nuclear power plant; airport

Discussion: Note Highway 61. This is the highway that caused problems 12 years ago. Belle View is approximately the same distance from the observatory: this is the town that just switched to high-pressure sodium lights. The fact that this town is on the other side of the river implies that it is a wealthier suburb: they can afford the initial cost of the high-pressure sodium lights. It is, indeed, the light from these lamps that is fogging the film. A check of the emission spectrum of this sodium light reveals why it is not so easy to filter this light.

Review interviews with engineer and astronomer; literature; compare to other maps. Check Sleuth Info on radar to eliminate it as a problem.

13. 10-year-old map of area

Clues: Significant growth from 40-year-old map; town between airport and observatory

Distractors: Airport; nuclear power plant

Discussion: This shows the area at about the time that it last caused problems for the observatory. Note the new highway that has mercury vapor lights before they changed. Compare to other maps; review interviews with astronomer and engineer; literature.

14. 25-year-old map of area

Clues: Nothing near observatory

Discussion: Compare to other maps.

15. Precipitation table

Clues: None

Distractors: Precipitation on several days each month

Discussion: Compare this to the initial interviews and the observatory log: the fogging does not correlate with weather.

16. Lunar phase chart for past year

Clues: None

Distractors: Full moon every month

Discussion: Compare this to the initial interviews and the observatory log: the fogging does not correlate with lunar phases.

17. Electromagnetic spectrum chart

Clues: None

Discussion: This illustrates the range of possibly interactive electromagnetic waves. Discuss each part of the spectrum: how do we use each of these waves? Read Sleuth Info on visible light spectrum.

18. Emission spectra of various lights

Clues: Low-pressure sodium has very narrow spectrum; high-pressure sodium has a lot of intensity at many wave lengths, even more than the mercury vapor lamp.

Distractors: Other lights

Discussion: Emission spectra typically fall into a series of well-defined spikes. Since white light contains light from many parts of the color spectrum, it will show a wide band of emission spectra, not isolated spikes. This clarifies the problems with certain kinds of lights: imagine if fluorescent lights were brighter or closer to the observatory. Compare to the electromagnetic spectrum chart: where do these lights fit on that chart? Review interview with astronomer and discuss filtering: why is it so difficult to filter some of these lights? Read Sleuth Info on visible light spectrum.

19. Visible light spectrum

Clues: None

20. Radar

Clues: Radio waves have lower frequencies than light waves.

Distractors: Optical radars

Discussion: Because radar operates on a completely different part of the electromagnetic spectrum, it will not interfere with film, no matter how sensitive, even x-ray film.

21. Recent observatory photo

Clues: Foggy

Discussion: Compare to last year's photo; note how evenly spread the fog is.

22. Last year observatory photo

Clues: Clear photograph

Discussion: Compare to other photos.

23. Recent short exposure photo

Clues: Clear but dark

Discussion: This shows less fogging, but only because the film has not been allowed to be exposed very long: the fog didn't show, but neither did any of the details in the photograph.

24. Photo taken with dirty lens

Clues: Smear

Discussion: Compare to recent fogged photo. This is blurred in a different way; the fogged photo is sort of "grayed-out."

25. Photo taken with a jerky telescope motor

Clues: Blurred

Discussion: This is all blurred, but the colors and intensities are just as strong as one of last year's photos. Compare to both the recent photo and last year's photo.

26. Photo taken with old film

Clues: None

Discussion: The colors change with old film, but there is no "graying-out" or fogging of the film. Compare with both the recent and last year's photos.

27. Light leak test

Clues: None

Discussion: This illustrates film from a camera with a light leak. There are no signs of flares like these with the observatory's photos.

VOCABULARY

cathode-ray tube, cordon, correlation, frequencies, incandescence, lunar, megahertz, nanometers, purported, refracting, spectrum, wave lengths

FOR FURTHER STUDY

SCIENCE THEMES

Astronomy; visible light; light spectrum; x-rays; electromagnetic spectrum; lunar phases; radiation; meteorology; radar

SCIENCE SKILLS

Telescope; schematic diagrams; maps; electromagnetic spectrum; emission spectra; radar; photography

SCIENCE CAREERS

Astronomer; city and electrical engineers; physicist; photographer; radiologist; meteorologist

CROSS-CURRICULAR THEMES





Toxic transport; conservation efforts; city and highway planning; news broadcasting and media; city and county government; airport security

HOMETOWN EXTENSIONS

Discuss the different kinds of lights used in your community. Students can take notes for a week, observing lighting on streets, in homes, in businesses, and in school. Why were each of these lights selected?

RESOURCES Science Sleuths, Side B





INTERVIEWS

1. SCENE SET: Observatory
director
37145
(play) 
2. Astronomer
37609
(play) 
3. City engineer
38500
(play) 
4. News report on toxic spill
near nuclear power plant
39047
(play) 

DOCUMENTS











5. Observatory log
40046
(step) 

LITERATURE SEARCH







6. Search on the words
AIRPORT, CAREY COUNTY,
LIGHTING, HIGHWAY,
OBSERVATORY, SPILL,
X-RAYS
40049
(step) 
7. Article #1 ("The X-ray
Machine and You")
40052
(step) 
8. Article #2 ("Ammonia Spill
on Highway 61")
40056

9. Article #3 ("Council Member
Proposes New Lights")
40058
(step) 
10. Article #4 ("Lights Cast a
Shadow")
40061



SCIENCE INFORMATION SERVICE

11. Schematic diagram of telescope
40063 
12. Current map of the area
40065 
13. 10-year-old map of area
40067 
14. 25-year-old map of area
40069 
15. Precipitation table
40071
(step) 
16. Lunar phase chart for past year
40075 
17. Electromagnetic spectrum chart
40077 
18. Emission spectra of various lights
40079
(step) 
19. Visible light spectrum
40085
(step) 
20. Radar
40088
(step) 

STILL PHOTOGRAPHS

21. Recent observatory photo
40092
(step) 
22. Last year observatory photo
40094 
23. Recent short exposure photo
40096 
24. Photo taken with dirty lens
40098 
25. Photo taken with a jerky telescope motor
40100 
26. Photo taken with old film
40102 
27. Light leak test
40104 



◀ STEP REVERSE



PLAY ▶



STEP FORWARD ▶

Chapter 19 - Exam

Section	Number of Questions	Point Value Per Question	Total Possible Points (100)
Testing Concepts <ul style="list-style-type: none">• True/False• Multiple Choice	<ul style="list-style-type: none">• 15• 15	<ul style="list-style-type: none">• 2• 2	<ul style="list-style-type: none">• 30• 30
Understanding Concepts <ul style="list-style-type: none">• Short Answer• Fill-In-The-Blank• Concept Mapping	<ul style="list-style-type: none">• 1• 3• 1	<ul style="list-style-type: none">• 5• 3• 6	<ul style="list-style-type: none">• 5• 9• 6
Applying Concepts <ul style="list-style-type: none">• Short Answer	<ul style="list-style-type: none">• 5	<ul style="list-style-type: none">• 4	<ul style="list-style-type: none">• 20

Grading Scale

A = 100-93 B = 92-86 C = 85-76 D = 75-70 F = 69 and below

Chapter 19

CHAPTER REVIEW

• Light

Part A. Vocabulary Review

Match each definition with the correct term below. Write the correct terms in the blanks provided. When all the blanks have been filled, the letters in the vertical box will spell the name of an important class of waves.

diffraction
photons
modulation

incandescent
gamma
ultraviolet

opaque
microwaves
reflection

fluorescent
radiation
refraction

infrared
visible
transparent

Definitions

- | | |
|---|---|
| <ol style="list-style-type: none"> 1. light produced by heat 2. the bouncing of a wave from an object 3. materials that absorb or reflect nearly all light and cannot be seen through 4. the bending of waves around a barrier 5. bundles of radiation that have no mass 6. radiation that makes your skin feel warm 7. radio waves of the highest frequency and energy 8. process of varying radio waves | <ol style="list-style-type: none"> 9. transfer of energy by electromagnetic waves 10. highest frequency electromagnetic waves 11. materials that allow nearly all light to pass through 12. type of light that produces little heat 13. radiation that tans your skin 14. radiation you can see 15. the bending of light waves caused by a change in their speed |
|---|---|

Answers

<ol style="list-style-type: none"> 1. 2. 3. 4. 5. 6. 7. 8. 9. 10. 11. 12. 13. 14. 15. 	_ _	_ _ _ _ _ _ _ _ _ _ _ _ _ _ _	_ _
--	---	---	---

"Hidden" word: _ _ _ _ _

Chapter 19 Review (continued)

Part B. Concept Review

In the blank at the left, write the term that correctly completes each statement.

- _____ 1. The shorter the wavelength of an electromagnetic wave, the _____ its frequency.
 - _____ 2. Unlike other types of waves, electromagnetic waves do not need a _____ to transfer energy.
 - _____ 3. The electromagnetic waves used in communications are _____.
 - _____ 4. Virtually no light can pass through _____ materials.
 - _____ 5. Incandescent light is produced by _____.
 - _____ 6. A blue filter _____ red light.
 - _____ 7. The primary _____ colors are magenta (red), cyan (blue), and yellow.
 - _____ 8. When light waves pass from one medium to another they are _____.
 - _____ 9. White light can be separated into its individual colors by a glass prism or a _____.
 - _____ 10. A _____ is a three-dimensional image that seems to float in space.
 - _____ 11. Electromagnetic waves with the highest frequencies are _____.
 - _____ 12. When a light wave is reflected, the angle of reflection is _____ the angle of incidence.
 - _____ 13. When white light strikes a red object, all colors except red are _____.
 - _____ 14. Some light can pass through a _____ material, but you cannot see through it.
 - _____ 15. In the visible spectrum, _____ light has the shortest wavelength.
 - _____ 16. The retina is made up of two types of nerve cells called _____.
17. Arrange the following types of radiation in order from highest to lowest frequency: X rays, visible, radio waves, gamma rays, infrared, microwaves.
- _____

18. Arrange the colors of the visible spectrum in order from longest to shortest wavelength.
- _____

Answer the following question on the lines provided.

19. What color is produced when the primary color pigments are mixed together? Explain.
- _____
- _____

Chapter 19

CHAPTER REVIEW

● Light

Part A. Vocabulary Review

Match each definition with the correct term below. Write the correct terms in the blanks provided. When all the blanks have been filled, the letters in the vertical box will spell the name of an important class of waves.

diffraction	incandescent	opaque	fluorescent	infrared
photons	gamma	microwaves	radiation	visible
modulation	ultraviolet	reflection	refraction	transparent

Definitions

- | | |
|---|--|
| 1. light produced by heat | 9. transfer of energy by electromagnetic waves |
| 2. the bouncing of a wave from an object | 10. highest frequency electromagnetic waves |
| 3. materials that absorb or reflect nearly all light and cannot be seen through | 11. materials that allow nearly all light to pass through |
| 4. the bending of waves around a barrier | 12. type of light that produces little heat |
| 5. bundles of radiation that have no mass | 13. radiation that tans your skin |
| 6. radiation that makes your skin feel warm | 14. radiation you can see |
| 7. radio waves of the highest frequency and energy | 15. the bending of light waves caused by a change in their speed |
| 8. process of varying radio waves | |

Answers

- | | | | | | | | | | | | | | | | | | |
|-----|---|---|---|---|---|---|---|---|---|---|---|---|---|---|---|---|---|
| 1. | L | N | C | A | N | D | E | S | C | E | N | I | | | | | |
| 2. | | | | R | E | E | L | E | C | T | L | O | N | | | | |
| 3. | | | | O | P | A | Q | | | | | | | | | | |
| 4. | D | I | F | E | R | A | C | I | L | O | N | | | | | | |
| 5. | | | | P | H | O | T | I | O | N | S | | | | | | |
| 6. | L | N | E | R | A | R | E | D | | | | | | | | | |
| 7. | | | | M | I | C | R | O | N | A | W | A | V | E | S | | |
| 8. | | | | | | | M | O | D | U | L | A | T | I | O | N | |
| 9. | | | | R | A | D | I | A | T | I | O | N | | | | | |
| 10. | | | | | | | G | A | M | M | A | | | | | | |
| 11. | | | | | | | I | R | A | N | S | P | A | R | E | N | I |
| 12. | E | L | U | V | O | R | E | S | C | E | N | I | | | | | |
| 13. | | | | | | | U | L | T | R | A | V | I | O | L | E | I |
| 14. | | | | | | | V | I | S | A | B | L | E | | | | |
| 15. | R | E | F | E | R | A | C | I | L | O | N | | | | | | |

"Hidden" word: E L E C T R O M A G N E T I C

Chapter 19 Review (continued)

Part B. Concept Review

In the blank at the left, write the term that correctly completes each statement.

- HIGHER 1. The shorter the wavelength of an electromagnetic wave, the ___ its frequency.
- MEDIUM 2. Unlike other types of waves, electromagnetic waves do not need a
RADIO WAVES AND ___ to transfer energy.
- MICROWAVES 3. The electromagnetic waves used in communications are ___.
- OPAQUE 4. Virtually no light can pass through ___ materials.
- HEAT 5. Incandescent light is produced by ___.
- ABSORBS 6. A blue filter ___ red light.
- PIGMENT 7. The primary ___ colors are magenta (red), cyan (blue), and yellow.
- REFRACTED 8. When light waves pass from one medium to another they are ___.
- DIFFRACTION/SCATTERING 9. White light can be separated into its individual colors by a glass prism or a ___.
- HOLOGRAM 10. A ___ is a three-dimensional image that seems to float in space.
- GAMMA RAYS 11. Electromagnetic waves with the highest frequencies are ___.
- EQUAL TO 12. When a light wave is reflected, the angle of reflection is ___ the angle of incidence.
- ABSORBED 13. When white light strikes a red object, all colors except red are ___.
- TRANSLUCENT 14. Some light can pass through a ___ material, but you cannot see through it.
- VIOLET 15. In the visible spectrum, ___ light has the shortest wavelength.
- RODS AND CONES 16. The retina is made up of two types of nerve cells called ___.

17. Arrange the following types of radiation in order from highest to lowest frequency: X rays, visible, radio waves, gamma rays, infrared, microwaves.

GAMMA RAYS, X RAYS, VISIBLE, INFRARED, MICROWAVES, RADIO WAVES

18. Arrange the colors of the visible spectrum in order from longest to shortest wavelength.

RED, ORANGE, YELLOW, GREEN, BLUE, INDIGO, VIOLET

Answer the following question on the lines provided.

19. What color is produced when the primary color pigments are mixed together? Explain.

The mixture absorbs all the light that strikes it. No colors are reflected back from the mixture, so it appears black.

Summation and Evaluation

Holly Rubach
Eighth Grade
Physical Science
03-16-00
10:25 a.m. – 11:10 a.m.

Materials: For each student, a copy of the exam provided by the publisher of the text, Physical Science.

Estimated Time: 45 minutes

Lesson Objective: To assess the students' knowledge of the objectives for Chapter 19, Light.

Introduction: Today we are having our unit test. You will complete the test I am providing for you in this 45-minute period. Again, here is how I will grade this exam. <Put up transparency.>

Instructional Procedures: For this exam, you may use your spiral notebook and any of the handouts, labs, and homework assignments we have completed for Chapter 19. <Hand out the exam.> Monitor the class to keep the room quiet and to curb cheating. Let the students know how much time they have left near the end of the period. (At 10 minutes, 5 minutes.) As students finish the exam have them begin the reading assignment for the next chapter.

Evaluation: The following rubric will be used to grade the responses:

Section	Number of Questions	Point Value Per Question	Total Possible Points 100
Testing Concepts <ul style="list-style-type: none">• True/False• Multiple Choice	<ul style="list-style-type: none">• 15• 15	<ul style="list-style-type: none">• 2• 2	<ul style="list-style-type: none">• 30• 30
Understanding Concepts <ul style="list-style-type: none">• Short Answer• Fill-In-The-Blank• Concept Mapping	<ul style="list-style-type: none">• 1• 3• 1	<ul style="list-style-type: none">• 5• 3• 6	<ul style="list-style-type: none">• 5• 9• 6
Applying Concepts <ul style="list-style-type: none">• Short Answer	<ul style="list-style-type: none">• 5	<ul style="list-style-type: none">• 4	<ul style="list-style-type: none">• 20

Note: Short answer questions may be given partial credit.

Grading Scale

A = 100-93 B = 92-86 C = 85-76 D = 75-70 F = 69 and below

Chapter 19

CHAPTER TEST

● Light

I. Testing Concepts

Determine whether the italicized term makes each statement true or false. If the statement is true, write the word "true" in the blank. If the statement is false, write in the blank the term that makes the statement true.

- _____ 1. When light strikes a *transparent* material, most of the light is absorbed or reflected.
- _____ 2. The only type of radiation with a shorter wavelength than an X ray is a *gamma ray*.
- _____ 3. When light passes from one medium to another medium in which it travels *faster*, the light is bent away from the normal.
- _____ 4. In the visible spectrum, the color with the shortest wavelength is *red*.
- _____ 5. *Fluorescent* light is produced by heat.
- _____ 6. Sunscreen is used to protect the skin from *ultraviolet* radiation.
- _____ 7. The *shorter* the wavelength of a wave, the higher its frequency.
- _____ 8. The transfer of energy by electromagnetic waves is called *refraction*.
- _____ 9. The highest frequency *infrared* waves are microwaves.
- _____ 10. X rays have *more* energy than ultraviolet radiation.
- _____ 11. When light is *diffracted*, it bends around a barrier.
- _____ 12. Almost all of the light that strikes a mirror is *reflected* by the mirror.
- _____ 13. The angle at which light strikes a surface is called the angle of *reflection*.
- _____ 14. If white light passes through a red filter, all of the red wavelengths are *absorbed*.
- _____ 15. To make *green* paint, blue and yellow pigments are blended.

In the blank at the left, write the letter of the term or phrase that answers each question or best completes each statement.

- _____ 16. Electromagnetic waves _____.
- a. have no wavelength
b. transfer energy
c. require a medium
d. have no frequency
- _____ 17. The electromagnetic waves with the shortest wavelengths are _____.
- a. radio waves b. light
c. X rays d. gamma rays
- _____ 18. The primary pigment colors are _____.
- a. magenta, cyan, and yellow
b. red, blue, and green
c. yellow, blue, and green
d. white and black

Chapter 19 Test (continued)

- ____ 19. The wavelengths of _____ are slightly longer than those of light.
a. ultraviolet radiation c. infrared radiation
b. radio waves d. X rays
- ____ 20. The color _____ is produced by blending the primary pigments.
a. black b. white c. magenta d. cyan
- ____ 21. Fluorescent light bulbs _____ than incandescent lights.
a. do not last longer c. are less expensive
b. produce more heat d. use less energy
- ____ 22. If light waves change speed when they pass from one medium into another, the light will be _____.
a. reflected b. refracted c. diffracted d. separated
- ____ 23. _____ is evidence that light behaves as a wave.
a. Refraction b. Reflection c. Diffraction d. Interference
- ____ 24. Radio waves and _____ are used in communications.
a. microwaves c. infrared radiation
b. gamma rays d. ultraviolet radiation
- ____ 25. Objects containing heat can emit _____.
a. radio waves c. gamma rays
b. infrared radiation d. microwaves
- ____ 26. By the process of _____, radio waves are changed into electrical signals.
a. diffraction b. radiation c. modulation d. refraction
- ____ 27. All the wavelengths of the _____ make up white light.
a. visible spectrum c. electromagnetic spectrum
b. primary spectrum d. infrared spectrum
- ____ 28. All of the following are part of the electromagnetic spectrum EXCEPT _____.
a. microwaves b. ultrasonic waves c. white light d. fluorescent light
- ____ 29. _____ are the most penetrating kind of electromagnetic radiation.
a. Ultraviolet rays b. Microwaves c. X rays d. Gamma rays
- ____ 30. A diffraction grating can be used to _____.
a. modulate radio waves c. filter out ultraviolet radiation
b. separate colors of white light d. detect infrared radiation

II. Understanding Concepts

Skill: Observing and Inferring

Answer the following question on the lines provided.

1. Imagine that you are reading a book while sitting next to a window on a bright, sunny day. You decide to drink a tall glass of water as you read. As you set your glass down next to your book, you see a small line of colors on your book page. What would you infer is happening?
- _____
- _____

Chapter 19 Test (continued)**Skill: Outlining***Fill in the blanks on the outline below with the correct terms and examples.*

2. I. Types of matter in an object determine the amount of light it absorbs and reflects.
- A. _____ materials—absorb or reflect nearly all light and cannot be seen through
1. Examples
- a. _____
- b. _____
3. B. _____ materials—allow nearly all light to pass through
1. Examples
- a. _____
- b. _____
4. C. _____ materials—allow some light to pass through, but do not allow you to see clearly through them
1. Examples
- a. _____
- b. _____

Skill: Concept Mapping

5. Draw a portion of a concept map on the electromagnetic spectrum. Label one circle *light* and another circle *infrared radiation*. Draw two lines to connect these circles. Label one line *increasing frequency* and the other line *increasing wavelength*. Add arrows to these lines so that your concept map will be correct.

Chapter 19 Test (continued)**III. Applying Concepts****Writing Skills**

Answer the following questions on the lines provided.

1. How does food cook in a microwave oven? _____

2. Why is mixing the primary colors of light an additive process while blending the primary pigment colors a subtractive process? _____

3. Describe the medical applications of the following types of radiation: infrared, ultraviolet, X rays, and gamma rays. _____

4. What causes a rainbow to form? _____

5. Why can you see a clear image of yourself in a lake on a calm day but not on a windy day? _____

Chapter 19

CHAPTER TEST

● Light

I. Testing Concepts

Determine whether the italicized term makes each statement true or false. If the statement is true, write the word "true" in the blank. If the statement is false, write in the blank the term that makes the statement true.

AN OPAQUE

1. When light strikes a *transparent* material, most of the light is absorbed or reflected.

TRUE

2. The only type of radiation with a shorter wavelength than an X ray is a *gamma ray*.

TRUE

3. When light passes from one medium to another medium in which it travels *faster*, the light is bent away from the normal.

VIOLET

4. In the visible spectrum, the color with the shortest wavelength is *red*.

INCANDESCENT

5. *Fluorescent* light is produced by heat.

TRUE

6. Sunscreen is used to protect the skin from *ultraviolet* radiation.

TRUE

7. The *shorter* the wavelength of a wave, the higher its frequency.

RADIATION

8. The transfer of energy by electromagnetic waves is called *refraction*.

RADIO

9. The highest frequency *infrared* waves are microwaves.

TRUE

10. X rays have *more* energy than ultraviolet radiation.

TRUE

11. When light is *diffracted*, it bends around a barrier.

TRUE

12. Almost all of the light that strikes a mirror is *reflected* by the mirror.

INCIDENCE

13. The angle at which light strikes a surface is called the angle of *reflection*.

TRANSMITTED

14. If white light passes through a red filter, all of the red wavelengths are *absorbed*.

TRUE

15. To make *green* paint, blue and yellow pigments are blended.

In the blank at the left, write the letter of the term or phrase that answers each question or best completes each statement.

B

16. Electromagnetic waves _____.

a. have no wavelength
b. transfer energy

c. require a medium
d. have no frequency

D

17. The electromagnetic waves with the shortest wavelengths are _____.

a. radio waves b. light

c. X rays d. gamma rays

A

18. The primary pigment colors are _____.

a. magenta, cyan, and yellow
b. red, blue, and green

c. yellow, blue, and green
d. white and black

Chapter 19 Test (continued)

- C 19. The wavelengths of _____ are slightly longer than those of light.
 a. ultraviolet radiation c. infrared radiation
 b. radio waves d. X rays
- A 20. The color _____ is produced by blending the primary pigments.
 a. black b. white c. magenta d. cyan
- D 21. Fluorescent light bulbs _____ than incandescent lights.
 a. do not last longer c. are less expensive
 b. produce more heat d. use less energy
- B 22. If light waves change speed when they pass from one medium into another, the light will be _____.
 a. reflected b. refracted c. diffracted d. separated
- D 23. _____ is evidence that light behaves as a wave.
 a. Refraction b. Reflection c. Diffraction d. Interference
- A 24. Radio waves and _____ are used in communications.
 a. microwaves c. infrared radiation
 b. gamma rays d. ultraviolet radiation
- B 25. Objects containing heat can emit _____.
 a. radio waves c. gamma rays
 b. infrared radiation d. microwaves
- C 26. By the process of _____, radio waves are changed into electrical signals.
 a. diffraction b. radiation c. modulation d. refraction
- A 27. All the wavelengths of the _____ make up white light.
 a. visible spectrum c. electromagnetic spectrum
 b. primary spectrum d. infrared spectrum
- B 28. All of the following are part of the electromagnetic spectrum EXCEPT _____.
 a. microwaves b. ultrasonic waves c. white light d. fluorescent light
- D 29. _____ are the most penetrating kind of electromagnetic radiation.
 a. Ultraviolet rays b. Microwaves c. X rays d. Gamma rays
- B 30. A diffraction grating can be used to _____.
 a. modulate radio waves c. filter out ultraviolet radiation
 b. separate colors of white light d. detect infrared radiation

II. Understanding Concepts

Skill: Observing and Inferring

Answer the following question on the lines provided.

1. Imagine that you are reading a book while sitting next to a window on a bright, sunny day. You decide to drink a tall glass of water as you read. As you set your glass down next to your book, you see a small line of colors on your book page. What would you infer is happening?

White light from the sun is being split up into its individual colors of the spectrum by the glass and water. The glass and water act as a prism.

Chapter 19 Test (continued)**Skill: Outlining**

Fill in the blanks on the outline below with the correct terms and examples.

2. I. Types of matter in an object determine the amount of light it absorbs and reflects.

A. OPAQUE materials—absorb or reflect nearly all light and cannot be seen through

1. Examples

a. SCIENCE BOOK

b. CHALKBOARD

3. B. TRANSPARENT materials—allow nearly all light to pass through

1. Examples

a. WINDOW PANES

b. EYEGLASS LENSES

4. C. TRANSLUCENT materials—allow some light to pass through, but do not allow you to see clearly through them

1. Examples

a. FROSTED GLASS

b. WAXED PAPER

Skill: Concept Mapping

5. Draw a portion of a concept map on the electromagnetic spectrum. Label one circle *light* and another circle *infrared radiation*. Draw two lines to connect these circles. Label one line *increasing frequency* and the other line *increasing wavelength*. Add arrows to these lines so that your concept map will be correct.

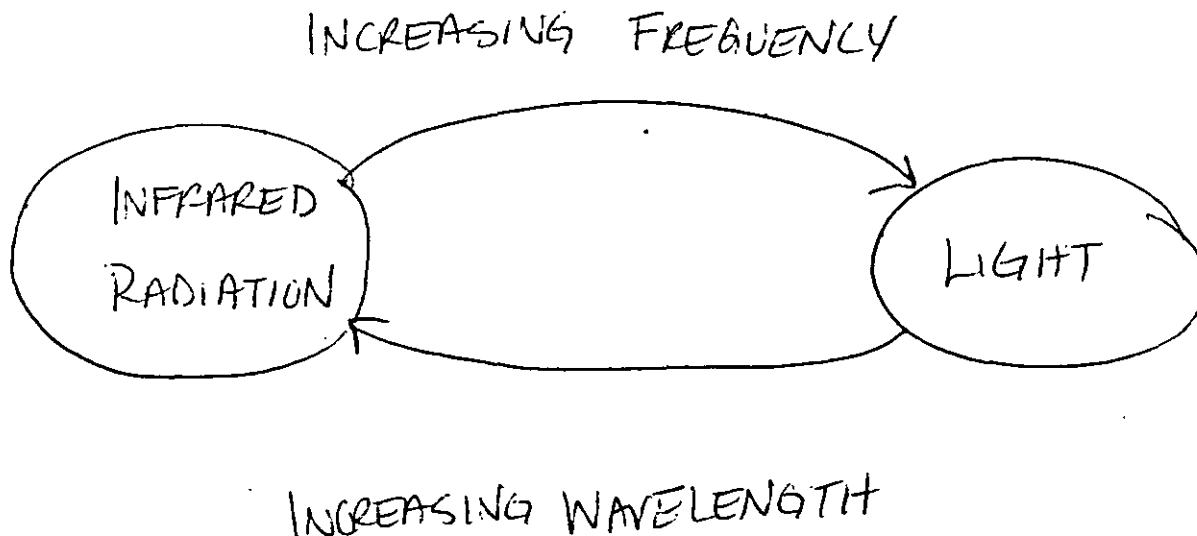

Chapter 19 Test (continued)**III. Applying Concepts****Writing Skills**

Answer the following questions on the lines provided.

1. How does food cook in a microwave oven? Microwaves carry energy into the molecules of the food. The molecules vibrate faster and rotate, thus changing the electromagnetic energy to kinetic energy. The increased motion increases the temperature of the food, causing it to "cook."
2. Why is mixing the primary colors of light an additive process while blending the primary pigment colors a subtractive process? As the different wavelengths are mixed, the wavelengths combine, or "add together" to produce white light. When the primary pigments are blended, the mixture absorbs, or "takes away" a "no light. This absence of reflected light is perceived as black.
3. Describe the medical applications of the following types of radiation: infrared, ultraviolet, X rays, and gamma rays. Infrared radiation (heat) given off by different parts of the body can be used to produce thermograms, which help doctors make diagnoses. Ultraviolet radiation can be used to kill germs in hospitals. X rays can be used to produce images of hard parts of the body, such as bones. Gamma radiation is used to kill cancer cells.
4. What causes a rainbow to form? When the sun shines during a rain shower, the raindrops act like individual prisms. Sunlight passing through the raindrops is separated into the individual colors of the visible spectrum, which creates the rainbow.
5. Why can you see a clear image of yourself in a lake on a calm day but not on a windy day? On a calm day, the surface of the lake is smooth and reflects your image back to you. On a windy day, the lake surface is rough and scatters the reflected light in all directions.

Evaluation

The student's work will be evaluated daily to check if the objectives for the lesson were met. When students have problems with a concept, I will review the lesson or make a note and follow through in the review period. There is a total of 415 possible points for this unit. That figure does not include the 20 bonus points that can be earned in Lesson 9. The following tables show a break down of the points.

<i>Lesson Number</i>	<i>Point Value</i>
<i>Lesson 1 (data sheet and 2 worksheets)</i>	55
<i>Lesson 2 (2 worksheets)</i>	24
<i>Lesson 3 (lab questions and graph)</i>	20
<i>Lesson 4 (2 worksheets)</i>	37
<i>Lesson 5 (data table, lab questions, and 2 worksheets)</i>	49
<i>Lesson 6 (data table and lab questions)</i>	20
<i>Lesson 7 (data table, lab questions, and worksheet)</i>	30
<i>Lesson 8 (lab questions and graph)</i>	20
<i>Lesson 9 (textbook review, lab report, and review worksheets)</i>	60 +20
<i>Lesson 10 (exam)</i>	100
TOTAL POINTS	415 +20

<i>Point Value</i>	<i>Letter Grade</i>
435 - 386	A
385 - 357	B
356 - 315	C
314 - 290	D
289 and below	F

March 2000

Unit Plan
LIGHT

Sun	Mon	Tue	Wed	Thu	Fri	Sat
			1	2	3	4
				Read Chapter 19	Lesson 1 The Electromagnetic Spectrum	
5	6	7	8	9	10	11
	Lesson 2 The Applications of Light	Lesson 3 How Bright is the Light?	Lesson 4 Light and Color	Lesson 5 Reflection	Lesson 6 Reflectivity of Light	
12	13	14	15	16	17	18
	Lesson 7 Applying Reflectivity of Light	Lesson 8 Polarized Light	Lesson 9 Unit Review	Lesson 10 Summation and Evaluation		
19	20	21	22	23	24	25
26	27	28	29	30	31	

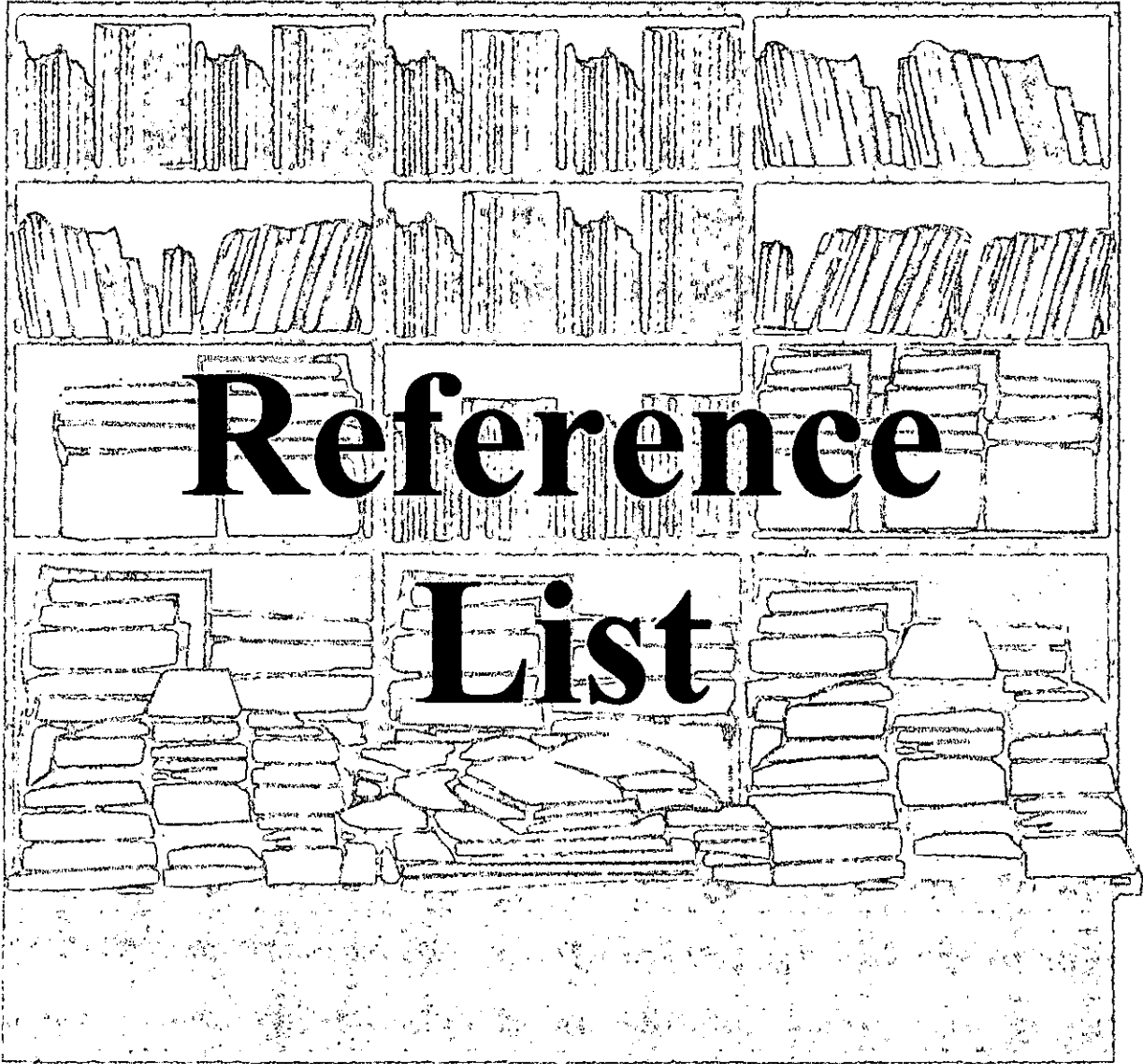

Reference

List

Works Cited

- Blecha, Milo K., and Raymond O'Toole. Activities for Exploring Matter and Energy. Irvine, California: Laidlaw Brothers, 1980.
- Brock, Ellen, Kristina Johnson, and Carol McLaren. Physics for Fun: Light Unit. Longmont, Colorado: Sopris West, 1993.
- Engaged Learning and Power Point. Effingham, Illinois: Effingham Unit 40, 1999.
- Hanna-Long, Mary and Tim Cotter. Internet Searching As a Tool in the Engaged Learning Process. Effingham, Illinois: Engaged Learning Projects, 1999.
- Johnson, Gordon P., Bonnie B. Barr, and Michael B. Leyden. Physical Science. Menlo Park, California: Addison Wesley, 1988.
- Maton, Anthea, et al. Exploring Physical Science. Englewood Cliffs, New Jersey: Prentice Hall, 1995.
- McKenzie, Jamieson. "Technology's Web." The School Administrator April 1998: 6-10.
- McLaughlin, Charles W. and Marilyn Thompson. Physical Science: Assessment – Chapter and Unit Tests. New York: Glencoe/McGraw-Hill, 1997.
- McLaughlin, Charles W. and Marilyn Thompson. Physical Science: Chapter Review. New York: Glencoe/McGraw-Hill, 1997.
- McLaughlin, Charles W. and Marilyn Thompson. Physical Science: Critical Thinking/Problem Solving. New York: Glencoe/McGraw-Hill, 1997.
- McLaughlin, Charles W. and Marilyn Thompson. Physical Science: Reinforcement – Teacher Edition. New York: Glencoe/McGraw-Hill, 1997.
- McLaughlin, Charles W. and Marilyn Thompson. Physical Science: Study Guide – Teacher Edition. New York: Glencoe/McGraw-Hill, 1997.
- McLaughlin, Charles W. and Marilyn Thompson. Physical Science: Teachers Wraparound Edition. New York: Glencoe/McGraw-Hill, 1997.
- Jones, B., Valdez, G., Nowakowski, J., & Rasmussen, C. "Designing Learning and Technology for Educational Reform." North Central Regional Educational Laboratory. <http://www.ncrel.org/sdrs/engaged.htm> (1 April 2000).
- Kalny, John. "Teaching in the Technology Age." Schools in the Middle May/June 1999: 18-21.

Nolan, Louise M. Physical Science: Teacher's Edition. Lexington, Massachusetts: Heath, 1987.

Perkins, Victoria L. "Effective Instruction Using Microcomputers." Academic Therapy November 1988: 129-35.

"School Reform and Student Diversity." September 1995. High Quality Learning Environments.
<http://www.ed.gov/pubs/SER/Diversity/sec-i4.html>

Skowron, Janice. "A Tool for Engaging Teachers in Change." Journal of Staff Development Winter 1998: 40-47.

Videodiscovery. Science Discovery: Science Sleuths. United States: Holt Rinehart and Winston, 1993.

Videodiscovery. Sleuth Resource Guidebook. Seattle: Holt Rinehart and Winston, 1994.